

# MAIN HEADING

sub heading



# Graphic Identity & Sign Guidelines Manual

Lorem ipsum dolor sit amet, consectetur adipiscing elit. Ut pharetra. Etiam tellus pede, consequat eu, placerat nec, commodo eget, eros. Morbi augue. Curabitur vitae odio. Aliquam id sapien ut lorem tempus feugiat. Curabitur eget elit sit amet velit adipiscing lobortis. Vestibulum sed ante id eros pretium ultrices. Nullam vel dolor.

Nulla vitae leo. Class aptent taciti sociosqu ad litora torquent per conubia nostra, per inceptos himenaeos. Aenean suscipit nunc laoreet purus. Curabitur ullamcorper.

Etiam tellus pede, consequat eu, placerat nec, commodo eget, eros. Morbi augue. Curabitur vitae odio. Aliquam id sapien ut lorem tempus feugiat. Curabitur eget elit sit amet velit adipiscing lobortis. Vestibulum sed ante id eros pretium ultrices. Nullam vel dolor.

**A collaboration of  
the Allegheny Trail  
Alliance and the  
Trail Town Program**



[www.trailtowns.org](http://www.trailtowns.org)

[www.atatrail.org](http://www.atatrail.org)

# TABLE OF CONTENTS

---

<b>1</b>	<b>General</b>
1.1	Introduction
1.2	Acknowledgements
1.3	Funding Sources
1.4	Getting Started
<b>2</b>	<b>Graphic Identity Guidelines</b>
2.1	Great Allegheny Passage
2.7	Trail Town Program
<b>3</b>	<b>General Graphic Specifications</b>
3.1	Typefaces
3.2	Directional arrows
3.3	Symbols, amenities and services
3.4	Symbols, prohibitory
3.5	Colors, finishes, and materials
<b>4</b>	<b>Typical Sign Locations</b>
4.1	Single parking area
4.2	Dual parking area
<b>5</b>	<b>Access Area Signs Guidelines</b>
5.1	Access Area Identification Sign
5.4	Information Kiosks
5.8	Town Story Panel
5.9	Town Map & Directory Panel
5.10	Trail Map Panel
5.11	Rules and Etiquette/Trail Stewardship
<b>6</b>	<b>On-Trail Signs Guidelines</b>
6.1	Trail Destinations
6.4	Town Amenities
6.7	Special Feature Identifiers
6.10	Special Feature Post Sign
6.13	Mile Marker
6.15	Trail Blazer
6.18	Heritage Interpretive Sign
<b>7</b>	<b>Roadway Signs Guidelines</b>
7.1	Supplemental Wayfinding
7.4	Reverse Wayfinding

# INTRODUCTION

Signs of progress



August, 2008

The Great Allegheny Passage has been over thirty years in the making. Over that period, a truly world-class trail has developed, along with thirty years of signage that, while needed, was uncoordinated. This trail system has become a major attraction in southwestern Pennsylvania and western Maryland, and tourism from the trail is valued at over \$12 million per year and growing. The trail required major capital investments from public and private sources, with the promise to not only build a trail, but to revitalize the economies of communities left behind by the railroads and industries that they served.

The Great Allegheny Passage is at a critical stage now. Assisted by the new Trail Town Program, an economic development initiative of The Progress Fund, it has the opportunity to show visitors that it has matured into a smart, well-appointed trail system. Trail users need and expect signage: to lead them to trail access areas; for rules and regulations; to describe the history and heritage of the region; to direct them to town services; and to orient and educate visitors.



The Trail Town Program, in partnership with the Allegheny Trail Alliance member organizations and several participating communities, has embarked on a project to redefine signage on the trail, both in terms of message and design. The team engaged ThoughtForm, a Pittsburgh design firm, to work with them to develop new sign protocols. ThoughtForm has extensive experience in developing wayfinding and signage for large public spaces.

The ATA, The Progress Fund, and the Trail Town Program invited trail groups and trail-related businesses to participate and offer their input. The organizations saw this opportunity as an excellent partnership—bringing the trail organizations to the table with business interests to address mutual goals. A “Sign Summit” was held in February 2008 to solicit general feedback and seek consensus. Then a follow-up meeting was held midway through the process for the trail organizations to see preliminary designs and examine the logic of the proposed system. The signage project had several goals: the sign panels and structure would be as “green” as possible within pricing constraints; structures would be designed so that volunteers could build them if trail organizations wished to assume that responsibility in-house; and the sign structures would be simple and clean in order to not detract from the beauty of the trail’s natural landscape or town streetscapes.

We anticipate that the new signs will be added to the trail corridor incrementally, over a period of years. There may be opportunities to bundle the production of several signs under single contracts, but the trail organizations may produce these signs at their own pace, depending on need and resources available. Future trail users will benefit from these efforts, and their experience on the Great Allegheny Passage will be enhanced as a system-wide signage program moves to completion.

Linda McKenna Boxx

*President, Allegheny Trail Alliance*

Cathy McCollom

*Regional Director, The Trail Town Program*

# ACKNOWLEDGEMENTS

Contributors and collaborators

## **Project Directors**

Linda McKenna Boxx, President,  
The Allegheny Trail Alliance  
[www.atatrail.org](http://www.atatrail.org)  
724.537.6900

Cathy McCollom, Regional Director,  
The Trail Town Program, an economic  
development initiative of The Progress Fund  
[www.trailtowns.org](http://www.trailtowns.org)  
[www.progressfund.org](http://www.progressfund.org)  
724.216.9160

## **Great Allegheny Passage Sign System and Guidelines Manual**

ThoughtForm Inc.  
[www.thoughtformdesign.com](http://www.thoughtformdesign.com)  
412.488.8600

## **Great Allegheny Passage Logos**

Adalberto Ortiz  
Al Ortiz Design  
[www.alortizdesign.com](http://www.alortizdesign.com)

## **Interpretive Trailside Exhibit System**

Bally Design  
[www.ballydesign.com](http://www.ballydesign.com)  
412.621.9009

## **International Symbols**

Society for Environmental Graphic Design  
[www.segd.org](http://www.segd.org)  
202.638.5555

## **Trail Town Program Logos and Maps**

Apollo Design Group  
[www.apollodesigngroup.com](http://www.apollodesigngroup.com)  
724.532.3930

## **Related Trail Standards**

*Potomac Heritage National Scenic Trail:  
Graphic Identity Guidelines for Trail Partners*  
Potomac Heritage National Scenic Trail Office,  
National Park Service, Harpers Ferry, WV  
[www.nps.gov/pohe](http://www.nps.gov/pohe)  
304.535.4016

The new signage system presented in these guidelines was developed under the direction of Linda Boxx and Cathy McCollom. Along with their colleagues, and representatives of various trail organizations, they provided valuable insight and perspective, leading to more attractive and functional family of signs.

ThoughtForm Inc. of Pittsburgh designed the new signage system and developed this guidelines manual. ThoughtForm is a design firm that specializes in bringing ideas to life, making complex topics understandable, and engaging people with striking design.

A number of other design consultants also contributed valuable time and expertise to the enhancement of the Great Allegheny Passage and the Trail Town Program brand identities with the design of logos, maps, and interpretive exhibits.

The Allegheny Trail Alliance and the Trail Town Program acknowledge the support of the National Park Service in the production of these guidelines. The Great Allegheny Passage is a segment of the Potomac Heritage National Scenic Trail, which is administered by the National Park Service.

The National Park Service offers graphic identity guidelines for trail partners of the Potomac Heritage National Scenic Trail.

Should you have questions about the application of any guidelines or require original digital artwork for signs, logos, symbols, or maps, contact the Allegheny Trail Alliance or the Trail Town Program.

# FUNDING RESOURCES

For trail and trail town improvement projects

---

**Fayette County Tourism  
Grant Program**

(Available late 2009)  
724.238.5661

**Somerset County Tourism  
Grant Program**

724.238.5661

**Westmoreland County Tourism  
Grant Program**

[www.co.westmoreland.pa.us](http://www.co.westmoreland.pa.us)  
724.238.5661

**Trail Town Program  
An economic development initiative  
of The Progress Fund**

[www.trailtowns.org](http://www.trailtowns.org)

**The Allegheny Trail Alliance**

[www.atatrail.org](http://www.atatrail.org)

**Foundation Center**

[www.foundationcenter.org](http://www.foundationcenter.org)

Your organization doesn't have to go it alone. There are many resources available to organizations seeking to improve the towns and trails of the Great Allegheny Passage.

Funding for signage for trail town businesses is available in Fayette, Somerset, and Westmoreland Counties through tourism grant programs. Somerset County grant applications are available by calling the Somerset County Chamber of Commerce or the Laurel Highlands Visitors Bureau. They are available in late December and due in February. In Westmoreland County, grant program applications are available online every year in late January and due by March. A grant program is being established for Fayette County and should be available in 2009.

For more information and other resources, contact the Trail Town Program, an economic development initiative of The Progress Fund; the Allegheny Trail Alliance; the Foundation Center; or other private foundations. Corporations who are invested in your community may also wish to support your project.

# GETTING STARTED

## How to use these guidelines

### These guidelines are divided into seven sections.

**Section 1**, including this page, provides general background and overview information. Don't skip these pages!

**Section 2, Logo Guidelines**, presents the various color and style formats of the Great Allegheny Passage and Trail Town Program logos, along with some general guidelines for using them correctly.

**Note:** These guidelines show a number of formats for the Great Allegheny Passage identity, for print, web, and apparel. However, the sign system uses just one format—Round—with rare exceptions.

**Section 3, General Graphic Specifications** shows detailed information about general graphic elements including type fonts, arrows, symbols, and colors. Look for codes on the fonts and colors pages—they are referenced later.

**Section 4, Sign Location Guidelines**, includes typical access area plans and shows where the trail signs should be located. Your location is probably similar to one of these plans.

**The remainder of the guidelines, Sections 5, 6, and 7**, show how to use, build, and lay out graphics for each sign in the Great Allegheny Passage sign family.

For each sign type, there are typically **three guide pages**. See the examples on this page.

The **Sign Overview Page** explains the purpose of the sign and where it is typically used. A cost range is suggested to help you budget your project.

The **Construction Specifications Page** shows how to build the sign and what materials and fasteners are needed.

**Note:** The sign post structures are simple enough to be made by trail groups with basic carpentry skills and access to standard shop tools. However, they may also be ordered through the Allegheny Trail Alliance or direct from a qualified sign fabricator.

The **Graphic Specifications Page** shows how to lay out a sign's graphic message(s) and how to produce the graphic panel. Remember, fonts and colors are keyed by code to Section 3!

**Note:** Most graphic panels should be produced by a qualified sign fabricator, but certain ones are available for order through [www.buildasign.com](http://www.buildasign.com). Don't worry, these are duly noted.

For a list of qualified sign fabricators, contact the Allegheny Trail Alliance or the Trail Town Program.



Sign Overview Page

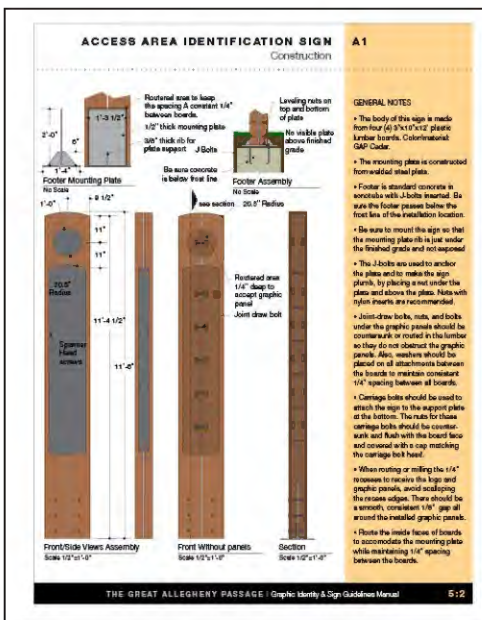

Construction Specifications Page

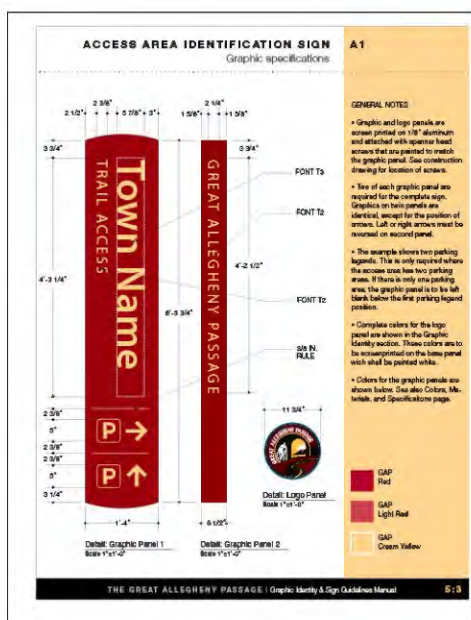

Graphic Specifications Page



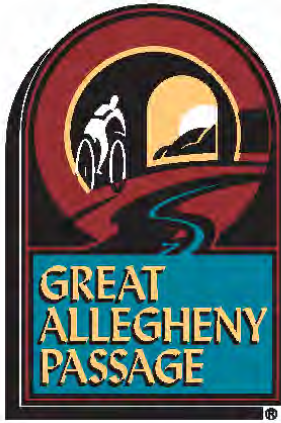

# GRAPHIC IDENTITY GUIDELINES

## Logo overview: Great Allegheny Passage

### Official Logo Formats



### Official Logo Colors

	<b>GAP Red</b> PMS 201 C=0, M=50, Y=32, K=14
	<b>GAP Blue</b> PMS 313 C=40, M=0, Y=4, K=7
	<b>GAP Yellow</b> PMS 141 C=0, M=10, Y=26, K=0
	<b>Black</b> K=100

The Great Allegheny Passage graphic identity is the most essential aspect of the trail brand. It establishes the Passage as a unified and significant trail system and as such encourages greater trail use as well as tourism in the adjacent trail town communities.

#### Logo Use

The three standard logo formats at left and the several variations on the following pages are the only approved identifying marks for the Great Allegheny Passage, and should always be used in accordance with the guidelines written in this document. For a complete description of the Allegheny Trail Alliance's policy on logo use by member and non-member organizations, please visit [www.atatrail.org/about/logo\\_policy.cfm](http://www.atatrail.org/about/logo_policy.cfm).

#### Registration Mark

The registration mark [®] must accompany the logo on all applications unless the application cannot accommodate the mark, such as on dimensional signage.

#### Color Palette

The official colors of the Great Allegheny Passage identity are listed at left, along with their Pantone Matching System (PMS) numbers and CMYK formulas. Whenever possible, use only these match numbers or formulas to maintain a consistent brand appearance. Exceptions are noted on following pages for one-color applications.

#### Reproduction

When reproducing any Great Allegheny Passage logo, always use original digital files provided by the Allegheny Trail Alliance. Please don't reproduce copies or use low-resolution digital files (.jpeg, .gif, .png, etc). Also, don't make changes to the original artwork except to change size. Wherever possible, use artwork with the .ai or .eps extensions to avoid quality loss when re-sizing the logo.

# GRAPHIC IDENTITY GUIDELINES

## Logo formats: Great Allegheny Passage

### Tombstone Format



### Horizontal Format



### Round Format



There are three format variations of the Great Allegheny Passage graphic identity. Choose the format that is most appropriate to your application.

#### Tombstone Format

Generally the preferred logo format, this format is ideal for print work and general applications.

#### Horizontal Format

Appropriate for apparel and smaller applications where the larger relative title size and distinct shape are desirable.

#### Round Format

The compact and simplified format is well-suited to signs and merchandise. Note this format does not include the "Pittsburgh to Cumberland Trail" tagline.

#### Color Variations

Overlaying the format variations are color variations. Each style may be reproduced in one of three coloration formats, or reversed as shown on page 2.3. See page 2.1 for Pantone match colors or for color ink formulas.

#### 4-Color (CMYK) Reproduction

- Black
- + GAP Red
- + GAP Yellow
- + GAP Blue

#### 2-Color Reproduction

- Black
- + GAP Blue

#### 1-Color Reproduction

- Black, GAP Red, or GAP Blue

#### OR

- Other spot color subject to ATA approval



# GRAPHIC IDENTITY GUIDELINES

Logo formats, continued: Great Allegheny Passage

## Tombstone Format, Sans Tagline



For very small logo applications that do not support the inclusion of the "Pittsburgh to Cumberland Trail" tagline, use one of these logo formats.

Use the special Web address identifier with discretion and only with approval of the Allegheny Trail Alliance. This format should appear only in 1-color or reversed coloration.

## Horizontal Format, Sans Tagline



## Special Web Address Format



# GRAPHIC IDENTITY GUIDELINES

## Reversed logo formats: Great Allegheny Passage

### Reversed



### 4-Color with Knockout



When applying the logo on dark or black backgrounds, follow one of these examples.

#### Reversed

The logo can be reversed out of dark or black background color if the paper or substrate color is white or lighter than 20% value. A reversed logo appears the same as 1-color logo except that all graphics are white.

#### 4-Color with Knockout

Any standard 4-color logo can appear on a dark background as long as the substrate color is white. Be sure to knock out the shape of the logo from the background color behind the logo so that the logo colors appear correct and white logo elements appear white. Avoid applying the 4-color logo to backgrounds that are darker than 80% because the black shadow and frame elements will be illegible against very dark or black backgrounds.

# GRAPHIC IDENTITY GUIDELINES

## Logo free space: Great Allegheny Passage

### Tombstone Format



### Horizontal Format



### Round Format



In order to preserve the logo's legibility, it is important to include a minimum space surrounding the logo that is always free of all other elements. This free space has been designed to be visually pleasing with the logo and should not be encroached upon by page borders, photos, graphics, text, or any other visual element.

To be representative of logos at any size, the width has been assigned a value of  $X$  in the diagrams. The minimum free space that should surround each logo format is indicated as some fraction of width  $X$  on each side of the logo, regardless of actual width. The shaded areas in the diagrams thus represent the minimum free space for each logo format.

# GRAPHIC IDENTITY GUIDELINES

## Improper logo use: Great Allegheny Passage



Don't change the logo coloration.



Don't stretch or otherwise distort the logo. Always re-size proportionally.



Don't use the two- or four-color logo for black & white or one-color reproduction. Use the one-color logo for this purpose.



Don't place the logo within another shape.



Don't alter the logo artwork in any way.

It is important for the integrity of the Great Allegheny Passage brand that the logo be applied consistently and professionally. Be sure not to alter or modify the logos from the original digital artwork in any way, with the exception of changing their size, which can be changed as needed, as long as the original proportions are maintained.

Some examples of improper use are shown at left. However, the only appropriate use of the logos is in their native form, as from the original digital artwork. Because there are so many official variations of the logo, there should never be any reason to modify the artwork to fit a particular application. If you have any question about your application, contact the Allegheny Trail Alliance.

# GRAPHIC IDENTITY GUIDELINES

## Logo overview: Trail Town Program

### Official Trail Town Program Logo



### Official Trail Town Logo Colors



#### Trail Town Light Blue

C=67, M=24, Y=15, K=0



#### Trail Town Yellow

C=10, M=45, Y=100, K=0



#### Trail Town Dark Blue

C=94, M=66, Y=22, K=5



#### Trail Town Red

C=25, M=78, Y=100, K=16



#### Trail Town Green

C=60, M=35, Y=100, K=17



#### Trail Town Light Red

C=4, M=6, Y=20, K=0

The Trail Town Program logos help to position the trail towns collectively and individually as substantial and worthy destinations for trail users. As such it encourages tourism in the trail town communities and greater trail use.

#### Logo Use

The round logo format shown at left for the Trail Town Program, as well as the individual town logos shown on the following page, are the only approved identifying marks for the Trail Town Program, and should always be used in accordance with the guidelines in this document.

#### Color Palette

The official colors of the Trail Town Program identity are listed at left, along with their CMYK formulas. Whenever possible, use these formulas to maintain a consistent brand appearance. Exceptions are noted on following pages for one-color applications.

#### Reproduction

When reproducing any Trail Town Program logo, always use original digital files provided by the Trail Town Program. Please don't reproduce copies or use low-resolution digital files (.jpeg, .gif, .png, etc). Also, don't make changes to the original artwork except to change size. Wherever possible, use artwork with the .ai or .eps extensions to avoid quality loss when re-sizing the logo.

# GRAPHIC IDENTITY GUIDELINES

## Logo formats: Trail Town Program

### Trail Town Program Official Color Variations



*Trail Town Dark Blue*



*Trail Town Red*



*Trail Town Green*

### Individual Trail Town Logos



### Color Variations

In addition to the standard 4-color and black and white colorations shown previously, the Trail Town Program logos can appear in one of three standard colors: Trail Town Dark Blue, Red, or Green. CMYK Formulas for these colors are shown on page 2.7.

Do not print the logo in the three lighter logo colors.

### Individual Town Logos

For each of several larger trail towns, there are individual iterations of the Trail Town logo which incorporate the town name. These logos offer the trail towns a means to brand themselves while leveraging the tourism value of a larger, connected system of towns.

Use these logos on communications that are specific to the town. If you are unsure of their use, contact the Trail Town Program.

# GRAPHIC IDENTITY GUIDELINES

## Reversed logo formats: Trail Town Program

### Reversed



When applying the logo on dark or black backgrounds, follow one of these examples.

### Reversed

The logo can be reversed out of a dark or black background color if the paper or substrate color is white or lighter than 20% value. A reversed logo appears the same as a 1-color logo, except that all graphics are white or light background color.

### 4-Color with Knockout

The standard 4-color logo can appear on a dark or black background as long as the paper or substrate color is white. Be sure to knock out the shape of the logo from the background color behind the logo so that the logo colors appear correct and white logo elements appear white.

### 4-Color with Knockout



# GRAPHIC IDENTITY GUIDELINES

Logo free space: Trail Town Program

## Standard Free Space



In order to preserve the logo's legibility, it is important to include a minimum space surrounding the logo that is always free of all other elements. This free space has been designed to be visually pleasing with the logo and should not be encroached upon by page borders, photos, graphics, text, or any other visual element.

To be representative of logos at any size, the width has been assigned a value of  $X$  in the diagrams. The minimum free space that should surround each logo format is indicated as some fraction of width  $X$  on each side of the logo, regardless of actual width. The shaded areas in the diagrams thus represent the minimum free space for each logo format.



# GRAPHIC IDENTITY GUIDELINES

## Improper logo use: Trail Town Program



Don't change the logo coloration.



Don't stretch or otherwise distort the logo. Always re-size proportionally.



Don't use the two- or four-color logo for black & white or one-color reproduction. Use the one-color logo for this purpose.



Don't place the logo within another shape.



Don't alter the logo artwork in any way.

It is important for the integrity of the Trail Town Program brand that the primary and individual town logos be applied consistently and professionally. Be sure not to alter or modify the logos from the original digital artwork in any way, with the exception of changing their size, which can be changed as needed as long as the original proportions are maintained.

Some examples of improper use are shown at left. However, the only appropriate use of the logos is in their native form, as from the original digital artwork. There should never be any reason to modify the artwork to fit a particular application. However, if you have any question about your application, contact the Trail Town Program.

# GENERAL GRAPHIC SPECIFICATIONS

## Typefaces and letter spacing

FONT T1: MYRIAD PRO LIGHT

ABCDEFGHIJKLMNOPQRSTUVWXYZ  
vwxyz1234567890

FONT T2: MYRIAD PRO REGULAR

ABCDEFGHIJKLMNOPQRSTUVWXYZ  
vwxyz1234567890

FONT T3: MYRIAD PRO SEMIBOLD

ABCDEFGHIJKLMNOPQRSTUVWXYZ  
vwxyz1234567890

FONT T4: MYRIAD PRO ITALIC

ABCDEFGHIJKLMNOPQRSTUVWXYZ  
vwxyz1234567890

FONT T5: MYRIAD PRO CONDENSED

ABCDEFGHIJKLMNOPQRSTUVWXYZ abcde-  
fghijklmnopqrstuvwxyz 1234567890

### System Typefaces

The type family Myriad Pro was chosen for the Great Allegheny Passage sign system because it is highly legible for signing purposes due to its proportions, comes in a variety of weights or styles which offers flexibility, and is already in use on map and promotional publications for the Trail Town Program and Great Allegheny Passage.

On graphic specifications drawings included in these guidelines, typefaces are keyed to this page with a two-character code.

(Example, T3 = Myriad Pro Bold)

Fonts can be purchased from Adobe Systems or its authorized dealers. See [www.adobe.com/type](http://www.adobe.com/type)

### Letter spacing guidelines

When setting type for sign messages, be sure they match the appearance of letter spacing—or tracking—shown in these guidelines. Typically, tracking for sign messages in these guidelines is 25 units. A tracking unit is equal to 1/1000 of an em (the width of the capital “M”). For special secondary messages, letter spacing is 150 spacing units. Other special cases are noted on individual drawings. Be sure to manually correct the kerning, or spacing, of characters like A, F, J, L, and T to correct for the extra white space integral to these characters.

*Standard Tracking = 25 Units*

*Special Tracking = 200 Units*

*Unit = 1/1000 em*

*em = Width of capital M*

# GENERAL GRAPHIC SPECIFICATIONS

## Directional arrows

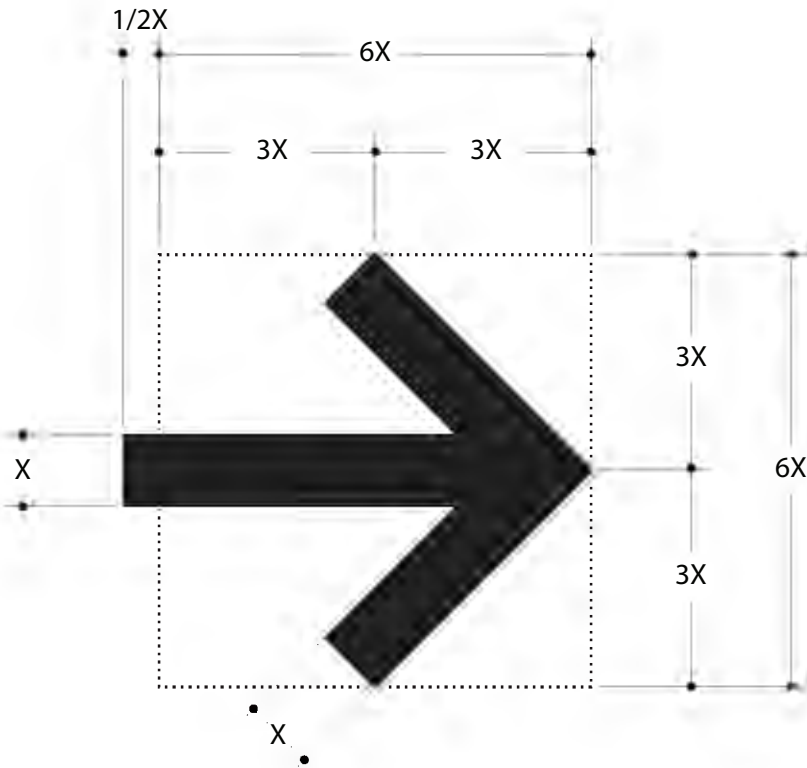

All directional signs in the GAP system use the arrow style shown here. Digital artwork for the arrow is available from the Allegheny Trail Alliance or the Trail Town Program, but it can also be mechanically drawn using these specifications. Never reproduce the arrow from this page.

Arrows are typically centered above or to the left of the accompanying directional legend. The drawings below show how to scale and position the arrow relative to the accompanying text, unless other specifications are given.

To set correct arrow height, match these inside corners to height of capital 'N'

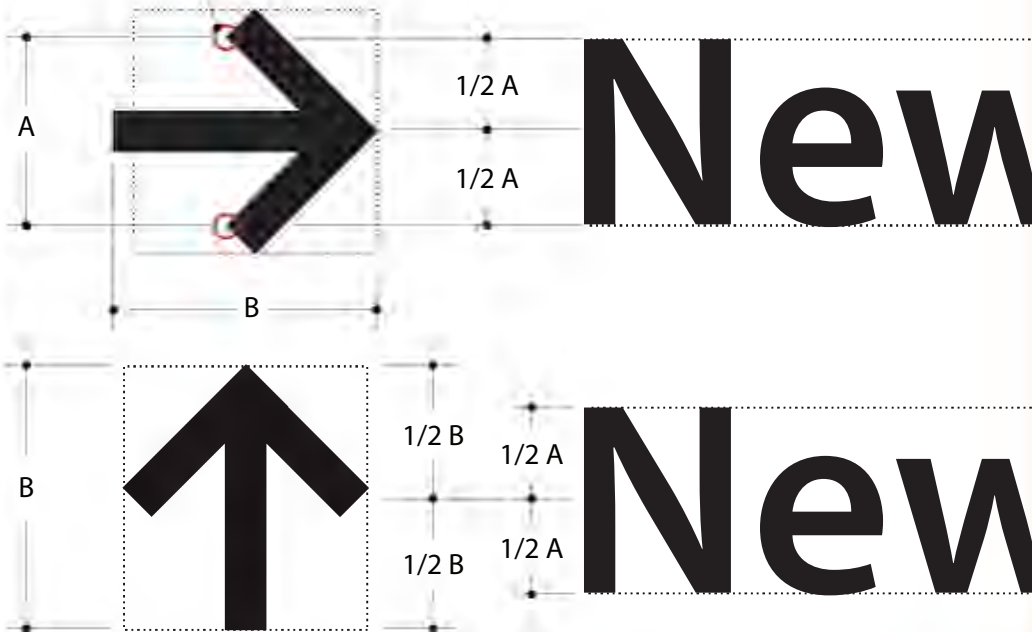

# GENERAL GRAPHIC SPECIFICATIONS

Symbols, amenities, and services



S.1 Bicycle Trail



S.2 Showers



S.3 Parking



S.4 Hiking Trail

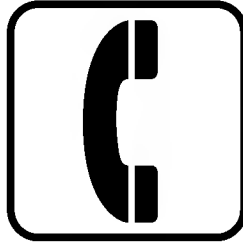

S.5 Telephone

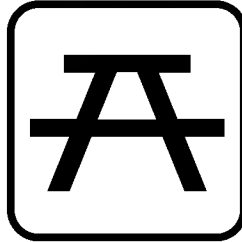

S.6 Picnic Site

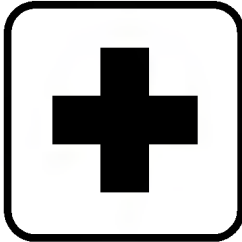

S.7 Hospital



S.8 Campground

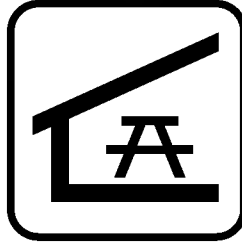

S.9 Picnic Shelter



S.10 Bus Stop



S.11 Lookout



S.12 Snack Bar



S.13 Grocery



S.14 Campfires



S.15 Information



S.16 Lodging

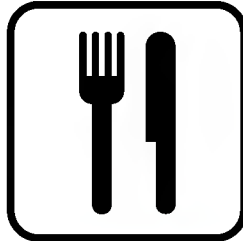

S.17 Restaurant/Food



S.18 Restrooms

Here are some common amenity symbols that can be used on directional signs and information kiosk panels.

These were developed by the Society for Environmental Graphic Design for use in recreational facilities. They relate closely to symbols developed by the American Institute of Graphic Arts (AIGA) for transportation graphics.

Do not reproduce symbols from this page. Use only digital art files provided by the Allegheny Trail Alliance or the Trail Town Program.

When ordering signs, indicate symbols by the code numbers listed here.

Graphic elements shown in black on this page will typically print GAP Light Yellow on signs, unless otherwise indicated. The areas inside the symbols that appear white on this page will be the background sign color, typically GAP Red.

# GENERAL GRAPHIC SPECIFICATIONS

## Symbols, prohibitory



S.20 No Smoking



S.21 No Firearms



S.22 No Campfires



S.23 No Fishing



S.24 No Littering



S.25 No Rock Collecting



S.26 No Firewood Cutting



S.27 No Climbing



S.28 No Camping



S.29 No Pets



S.30 No Motorcycles



S.31 No Horse Riding



S.32 No Parking



S.33 No Alcoholic Beverages

Here are some prohibitory symbols that can be used on trail regulation signs, at information kiosks, on bulletin boards, etc.

These symbols were developed by the Society for Environmental Graphic Design for use in recreational facilities. They relate closely to symbols developed by the American Institute of Graphic Arts (AIGA) for transportation graphics.

Do not reproduce symbols from this page. Use only digital art files provided by the Allegheny Trail Alliance or Trail Town Program.

When ordering signs, indicate symbols by the code numbers listed here.

For regulations signs included in these guidelines, these symbols will be digitally printed on white vinyl adhesive film. The white film is to be cut to the outer shape of the symbol. The black outline only defines the edge of the symbol—it should not be visible in the applied logo.

 WHITE  
(Substrate or vinyl color)

 Regulatory Red

 BLACK

# GENERAL GRAPHIC SPECIFICATIONS

Colors, finishes, and materials



## **GAP Red**

Paint or screenprint to match  
PMS 201 M as indicated on drawing



## **GAP Light Red**

Paint or screenprint to match  
PMS 7418 M as indicated on drawing



## **GAP Yellow**

Screenprint to match PMS 141 M



## **GAP Light Yellow**

Screenprint to match PMS 7401 M



## **GAP Blue**

Screenprint to match PMS 313 M or apply  
matching exterior grade matte vinyl as  
indicated on drawing



## **Black**

Screenprint to match PMS Black M or  
apply exterior grade matte black vinyl as  
indicated on drawing



## **White**

Screenprint to match PMS White M  
or apply exterior grade matte white vinyl  
as indicated on drawing



## **Reflective White**

Use 3M Scotchlite Diamond Grade  
980-10 White



## **Highway Blue**

Paint to match ASTM D4956  
Standard Highway Blue



## **Regulatory Red**

Print color digitally to match PMS 186 M

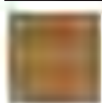

## **GAP Cedar**

Use "CEDAR" molded recycled HDPE  
plastic by Plastic Lumber Yard  
[www.plasticlumberyard.com](http://www.plasticlumberyard.com)

For all signs, colors and materials are labeled with simple color nicknames (i.e., GAP Blue) on construction and graphic specification drawings. These nicknames reference this page. Here, the color nicknames are paired with a PMS (Pantone Matching System) number for matching of inks or paints, or with a standard material with integral color (i.e., white vinyl).

Sign fabricators are familiar with the Pantone Matching System and regularly match colors to it.

Paints, inks, and vinyl films to be used for signs must be of the highest quality, and specifically formulated for fully exposed exterior sign applications.

# TYPICAL SIGN LOCATIONS

Example 1: Single parking lot

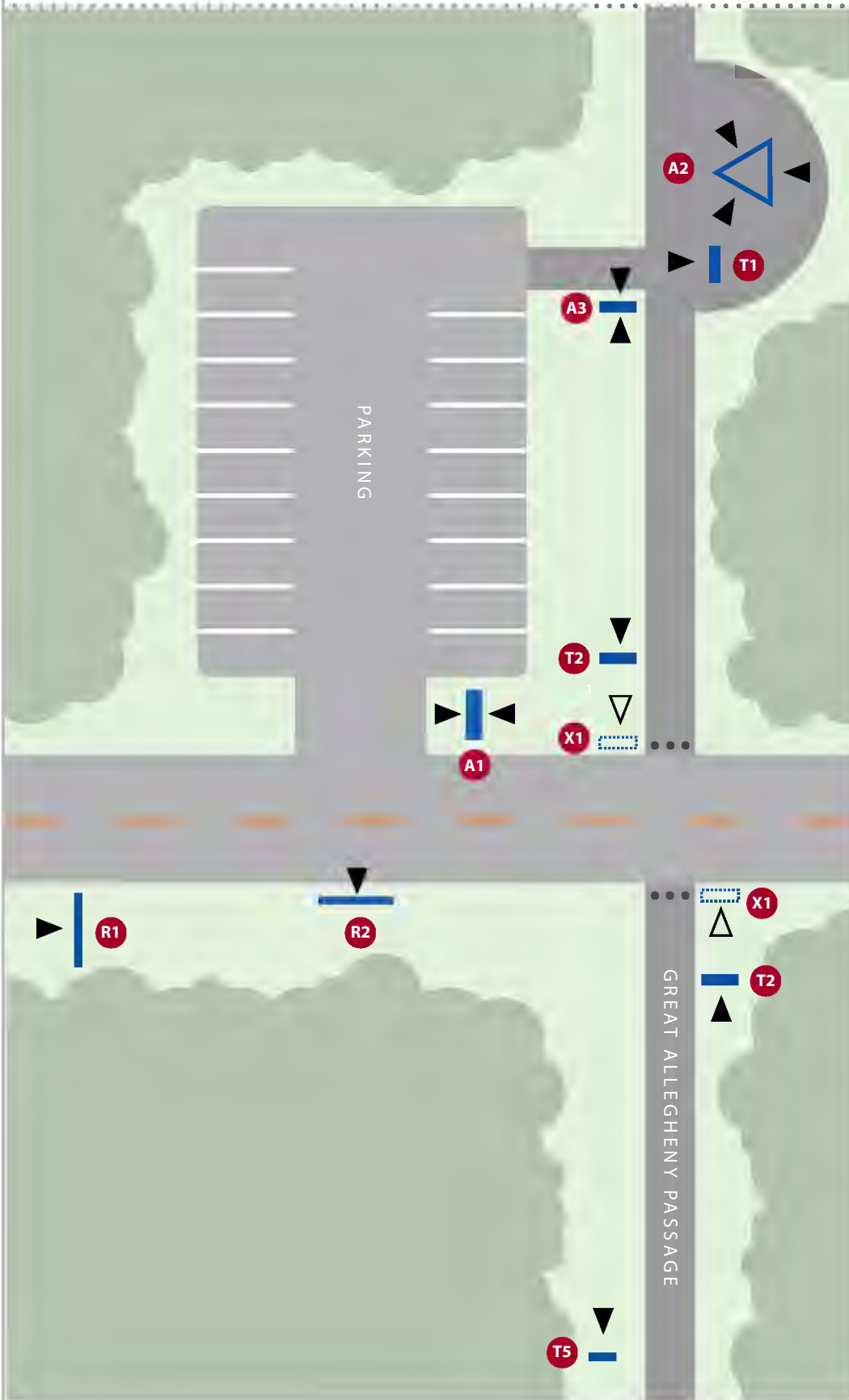

This diagram shows a typical trail access area for the Great Allegheny Passage with one parking lot. Your site condition may be a little different, so let empathy for the trail user and common sense guide the placement of signs for your project.

This diagram is not to scale and only indicates relative placement of signs to physical features. Actual sign placement will vary. Signs along roadways may be subject to local, state, or federal regulations.

Typical sign placements are described on sign overview pages which follow.

Small black triangles indicate viewing face or faces of signs.

Alphanumeric codes on the diagram correspond to the list below, the table of contents, and drawings for individual signs.

**R1 Supplemental Wayfinding Sign**  
*Typically located further from access area than shown.*

**R2 Reverse Wayfinding Sign**

**A1 Access Area Identification Sign**

**A2 Information Kiosk**  
*3-Panel version shown.*

**A3 Rules + Etiquette Sign**  
*May incorporate trail group recognition.*

**T1 Directional Sign: Trail Destinations**

**T2 Directional Sign: Town Amenities**

**T5 Mile Marker**  
*Existing mile markers will remain in place indefinitely.*

**X1 Stop Sign**  
*Not included in these guidelines. Follow state regulations for signing bicycle pathways.*

# TYPICAL SIGN LOCATIONS

## Example 2: Dual parking lot

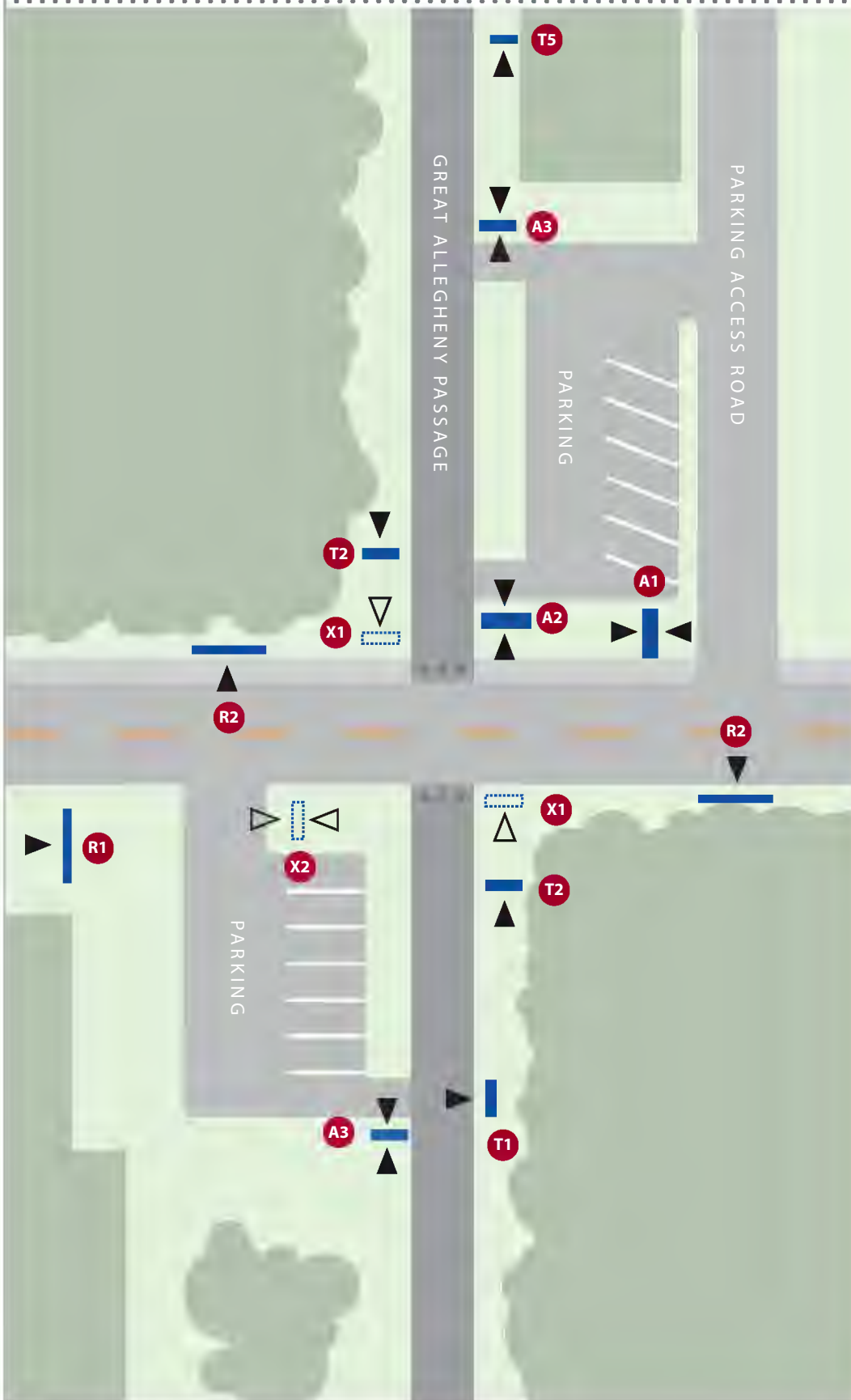

This diagram shows a trail access area with two parking lots flanking the access road.

The diagram is not to scale and only indicates relative placement of signs to physical features. Actual sign placement will vary. Signs along roadways may be subject to local, state, or federal ordinances or regulations.

Typical sign placements are described on sign overview pages which follow.

Small black triangles indicate viewing face or faces of signs.

Alphanumeric codes on the diagram correspond to the list below, the table of contents, and drawings for individual signs.

**R1** Supplemental Wayfinding Sign  
*Further from access area than shown.*

**R2** Reverse Wayfinding Sign

**A1** Access Area Identification Sign

**A2** Information Kiosk  
*2-Panel version shown.*

**A3** Rules + Etiquette Sign  
*Will incorporate trail group recognition on reverse side.*

**T1** Directional Sign: Trail Destinations

**T2** Directional Sign: Town Amenities

**T5** Mile Marker  
*Existing mile markers will remain in place indefinitely.*

**X1** Stop Sign  
*Not included in these guidelines. Follow state regulations for signing bicycle pathways.*

**X2** Supplemental Parking Identifier  
*Not included in these guidelines. Follow state regulations for vehicular signing.*



# ACCESS AREA IDENTIFICATION SIGN

## A1

### Overview

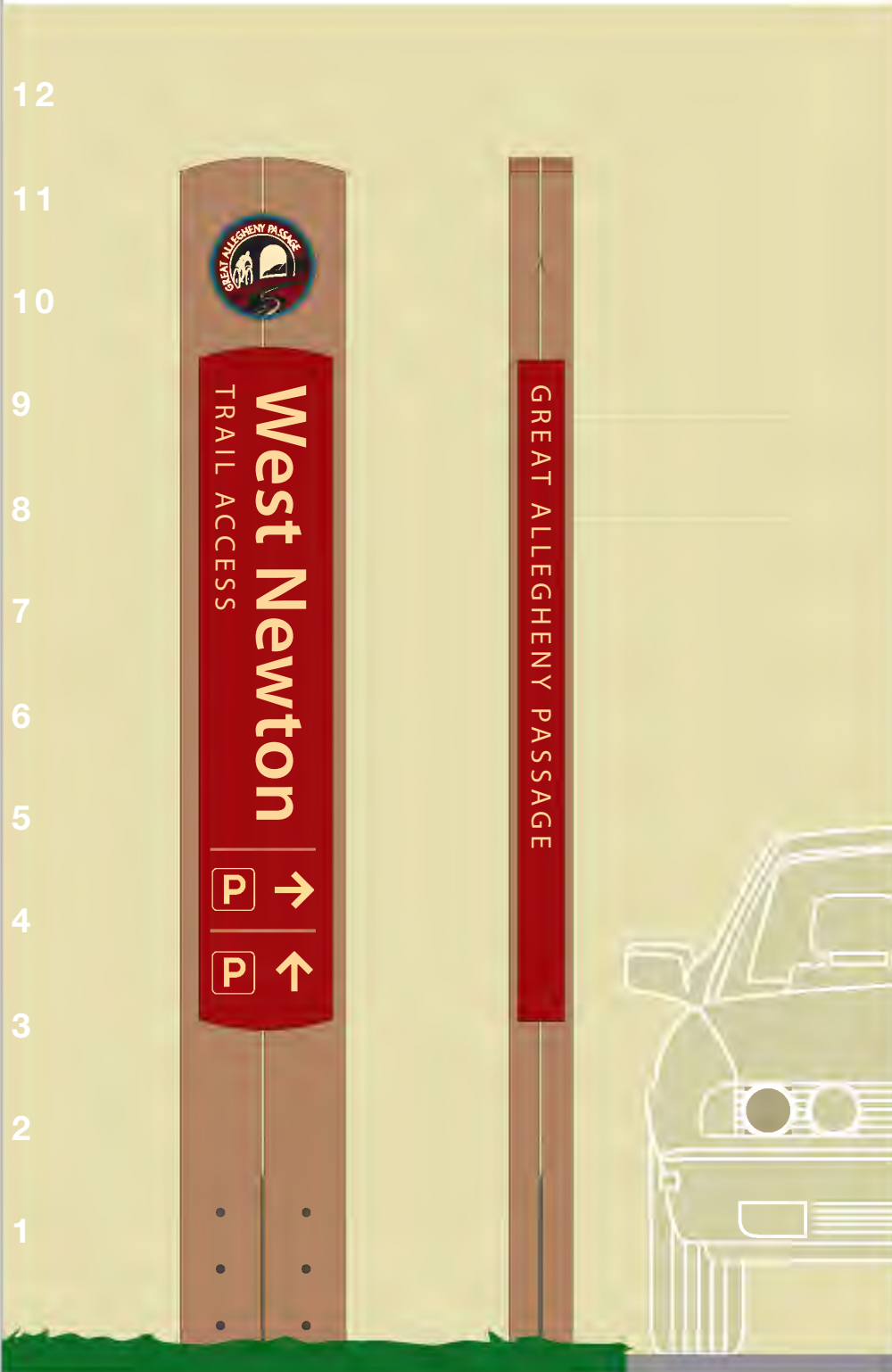

The Access Area Identification Sign announces the access area to approaching drivers and bicyclists, reinforces the Great Allegheny Passage brand with a prominently displayed logo, and provides direction to parking areas. The sign's height and unique shape provides greater visibility and recognition for approaching drivers and riders.

The sign is typically located near the parking area entrance, just outside of the public right of way. The sign should be positioned so that drivers have adequate time to turn once they see the parking directional arrow and make the decision to turn.

The example shown is for an access area with two parking lots.

The sign is double-sided with identical graphics on opposing sides, except for arrow positions.

Before installing this sign, review the design with your community planning board. It is ideal to maintain the continuity of this sign across all Great Allegheny Passage access areas; however, some community ordinances may prohibit the use of a sign of this height, or require a variance.

# ACCESS AREA IDENTIFICATION SIGN

A1

## Construction

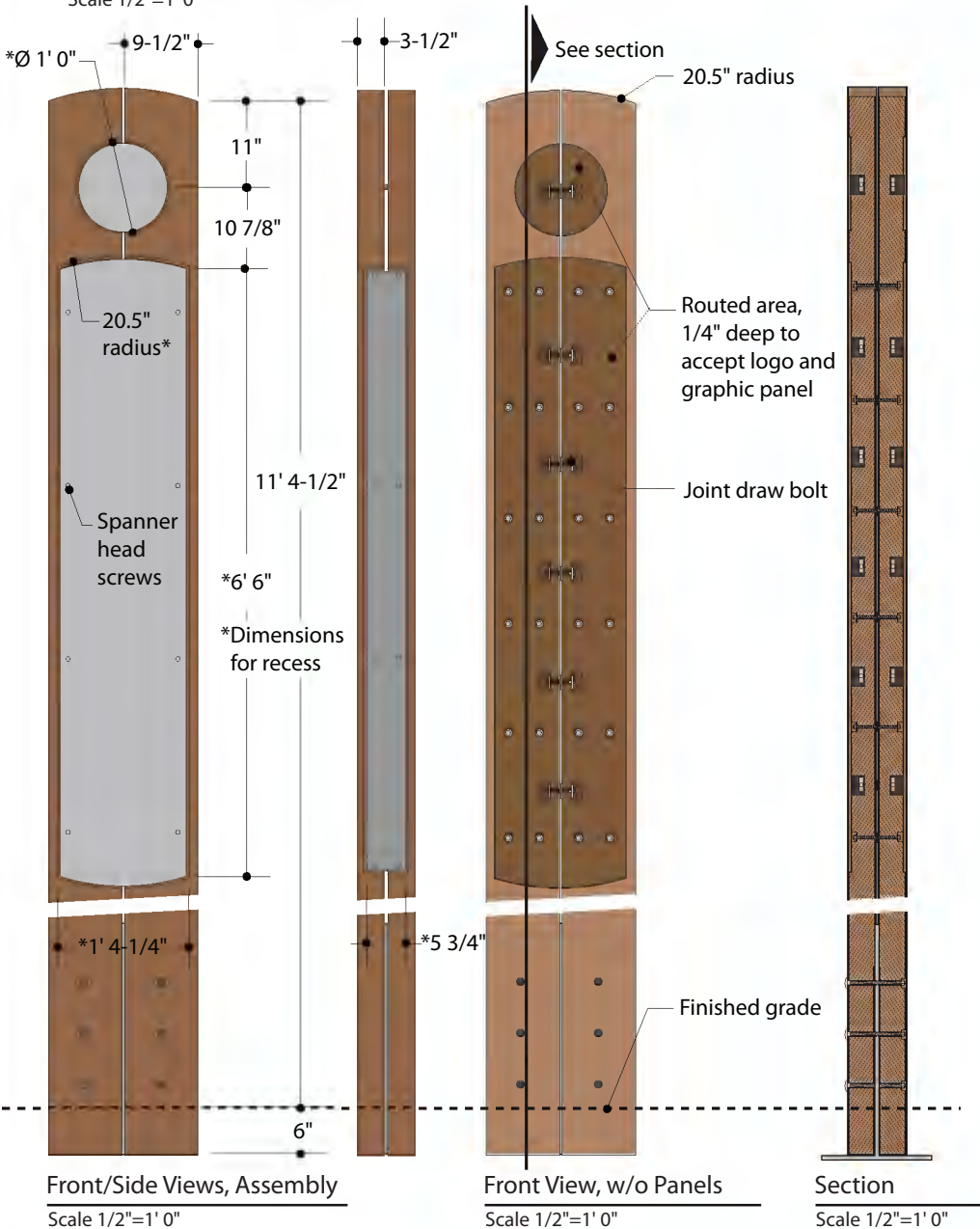
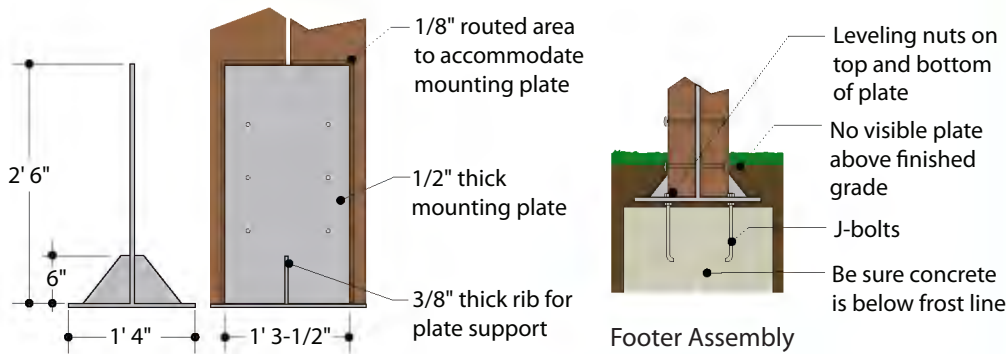

### GENERAL NOTES

- 1 The body of this sign is made from 4"x10"x12' plastic lumber. Color/material: GAP Cedar.
- 2 The mounting plate is welded from steel plate. For corrosion protection, the plate must be galvanized.
- 3 The footer is recycled concrete poured in a round form such as Sono-tube, with J-bolts inserted. Be sure the footer passes below the frost line of the installation location.
- 4 The footer and mounting plate must be set low enough that the mounting plate rib is just under the finished grade and not exposed.
- 5 By placing nuts on the J-bolts under and above the mounting plate, the plate can be adjusted level and plumb. Nuts with nylon inserts are recommended.
- 6 Joint draw bolts, nuts, and bolts behind the graphic panels must be countersunk or recessed in the lumber so they do not obstruct the graphic panels.
- 7 Washers should be placed on all attachments between the boards to maintain consistent 1/4" spacing between all boards.
- 8 The inside faces of boards are routed to accommodate the mounting plate while maintaining 1/4" spacing between the boards.
- 9 The sign is secured to the mounting plate with carriage bolts. The nuts for these carriage bolts should be countersunk and the holes covered with a cap matching the carriage bolt heads.
- 10 The 1/4" recesses to receive the logo and graphic panels must be free of scalloping. There must be a smooth, consistent 1/8" gap all around the installed graphic panels.

# ACCESS AREA IDENTIFICATION SIGN

A1

Graphic specifications

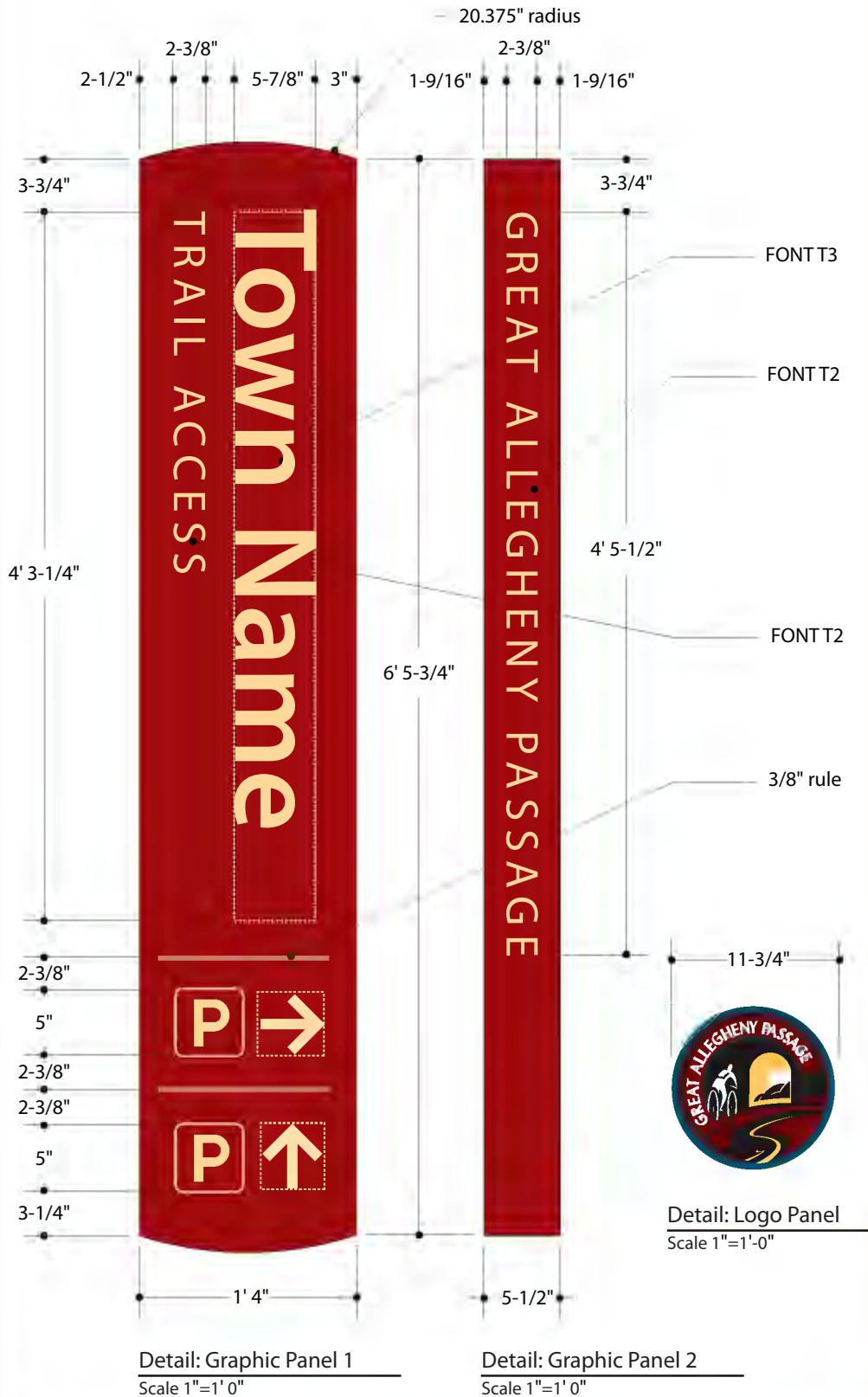

## GENERAL NOTES

**1** Graphic and logo panels are 1/8" painted aluminum sheet with screen-printed graphics and are attached to the plastic sign body with spanner head screws that are painted to match the graphic panel. See construction drawing for location of screws.

**2** Two of each graphic panel are required for the complete sign. Graphics on twin panels are identical, except for the position of arrows. Left or right arrows must be reversed on opposing twin panel.

**3** The example shows two parking legends. This is required only where the access area has two parking areas. If there is only one parking area, the graphic panel is to be left blank below the first parking legend position.

**4** Colors for the graphic panels are shown below. Edges and back of the graphic panel are painted same as the face color. See also page 3.5, Colors, Finishes, and Materials, for complete specifications.

**5** Complete colors for the logo panel are shown on page 2.1, Logo Overview. The edges and back of the logo panel are painted to match the outermost color of the logo.

**6** Messages outlined in dashed boxes may change. The dashed box indicates maximum extent of copy. Other messages should not change.



# INFORMATION KIOSKS

## Overview

## A2



Two-sided kiosk



Three-sided kiosk

Information Kiosks include two- and three-sided versions. Both formats employ identical post and panel details; only a metal angle strip changes to accept panels at a 90-degree angle (for two-sided), or at a 60-degree angle (for three-sided).

Typically located in or near trail access areas, information kiosks can display trail town maps and business directories, town welcome messages, and regional trail maps. They can also acknowledge trail maintenance organizations and volunteers.

Brochure holders integrated with the graphic panels can hold town and trail maps.

Kiosks which include trail town maps and directories should be situated so that the town map is oriented according to the physical world.

The information panels are produced using high-resolution digital printing technology on a vinyl film which is applied to a metal substrate. Trail town maps and directories may change out on an annual or semi-annual basis and this production method is suitably economical.

The area below and immediately around information kiosks should be carefully landscaped to minimize maintenance burden. Consider hard materials such as concrete, brick, cobblestones, or specialty materials that will prohibit weed growth.

# INFORMATION KIOSKS

## Construction for two-sided kiosk

A2/2

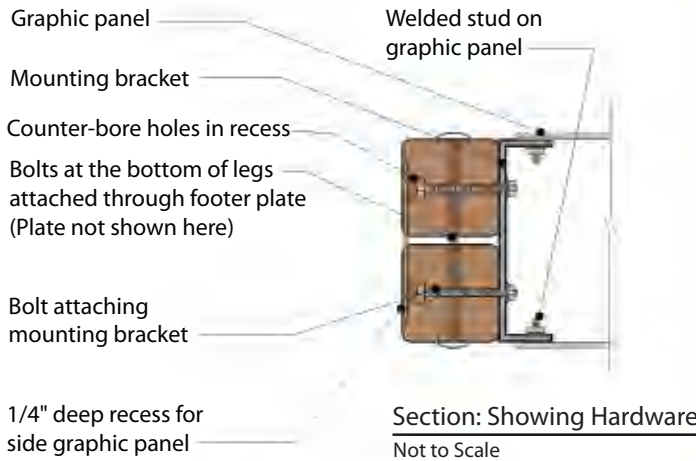

NOTE: Leg profile and assembly same as for three side kiosk; See page 5.6

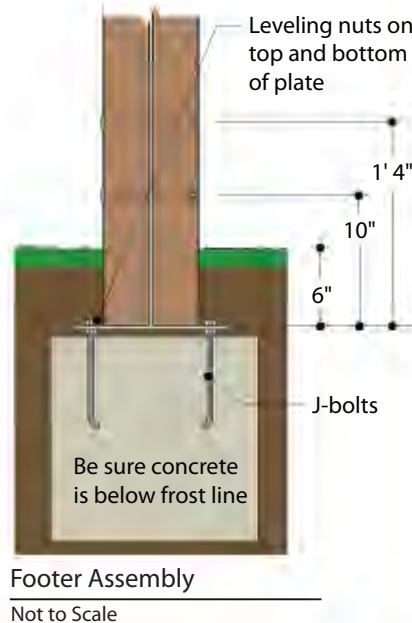
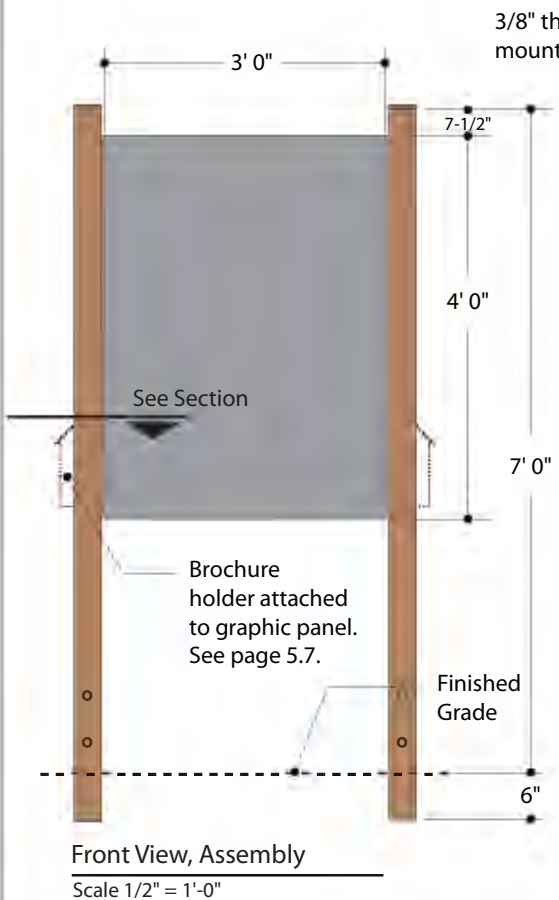
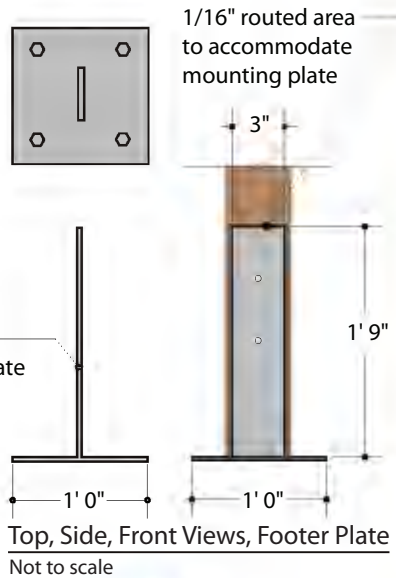
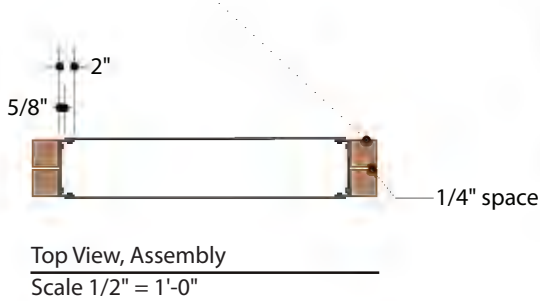

### GENERAL NOTES

**1** Kiosk legs are made from 4"x4"x8' plastic lumber. Color/material: GAP Cedar.

**2** The mounting plate is welded from steel plate. For corrosion protection, the plate must be galvanized.

**3** The footer is recycled concrete poured in a round form such as Sono-tube, with J-bolts inserted. Be sure the footer passes below the frost line of the installation location.

**4** The footer and mounting plate must be set low enough that the mounting plate rib is just under the finished grade and not exposed.

**5** By placing nuts on the J-bolts under and above the mounting plate, the plate can be adjusted level and plumb. Nuts with nylon inserts are recommended.

**6** Joint draw bolts, nuts, and bolts behind the graphic panels must be countersunk or recessed in the lumber so they do not obstruct the graphic panels.

**7** Washers should be placed on all attachments between the boards to maintain consistent 1/4" spacing between all boards.

**8** The inside faces of boards are routed to accommodate the mounting plate while maintaining 1/4" spacing between the boards.

**9** The sign is secured to the mounting plate with carriage bolts. The nuts for these carriage bolts should be countersunk and the holes covered with a cap matching the carriage bolt heads.

**10** The 1/4" recesses to receive the logo and graphic panels must be free of scalloping. There must be a smooth, consistent 1/8" gap all around the installed graphic panels.

# INFORMATION KIOSKS

## Construction for three-sided kiosk

A2/3

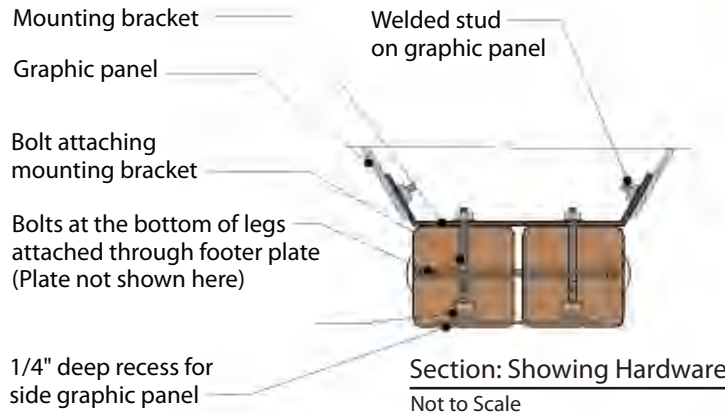

Note: Brochure holders attach to face of graphic panels on posts (Not shown). See page 5.7.

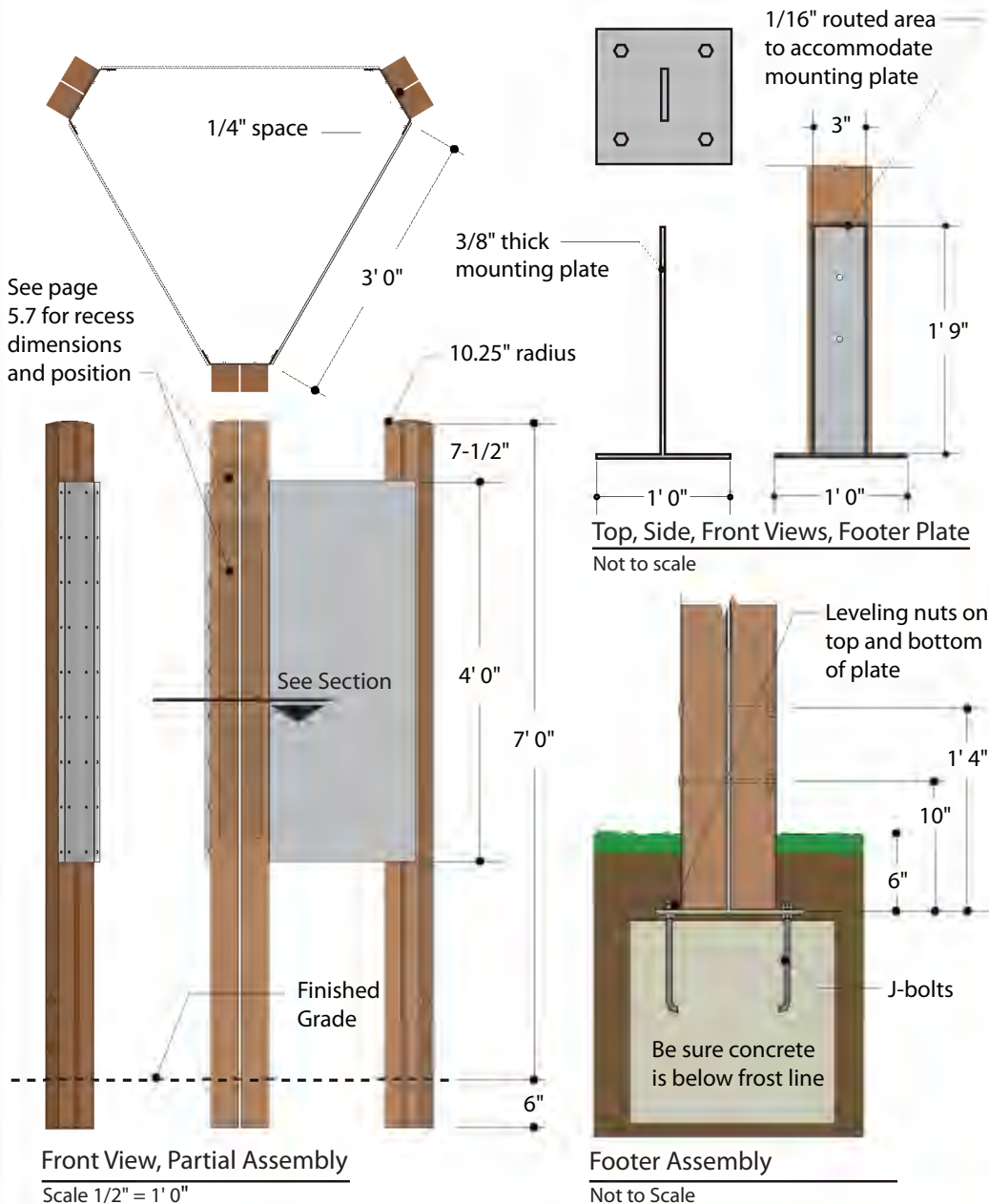

### GENERAL NOTES

- 1 Kiosk legs are made from 4"x4"x8' plastic lumber. Color/material: GAP Cedar.
- 2 The mounting plate is welded from steel plate. For corrosion protection, the plate must be galvanized.
- 3 The footer is recycled concrete poured in a round form such as Sono-tube, with J-bolts inserted. Be sure the footer passes below the frost line of the installation location.
- 4 The footer and mounting plate must be set low enough that the mounting plate rib is just under the finished grade and not exposed.
- 5 By placing nuts on the J-bolts under and above the mounting plate, the plate can be adjusted level and plumb. Nuts with nylon inserts are recommended.
- 6 Joint draw bolts, nuts, and bolts behind the graphic panels must be countersunk or recessed in the lumber so they do not obstruct the graphic panels.
- 7 Washers should be placed on all attachments between the boards to maintain consistent 1/4" spacing between all boards.
- 8 The inside faces of boards are routed to accommodate the mounting plate while maintaining 1/4" spacing between the boards.
- 9 The sign is secured to the mounting plate with carriage bolts. The nuts for these carriage bolts should be countersunk and the holes covered with a cap matching the carriage bolt heads.
- 10 The 1/4" recesses to receive the logo and graphic panels must be free of scalloping. There must be a smooth, consistent 1/8" gap all around the installed graphic panels.

# INFORMATION KIOSKS

Specifications for post graphics

## A2

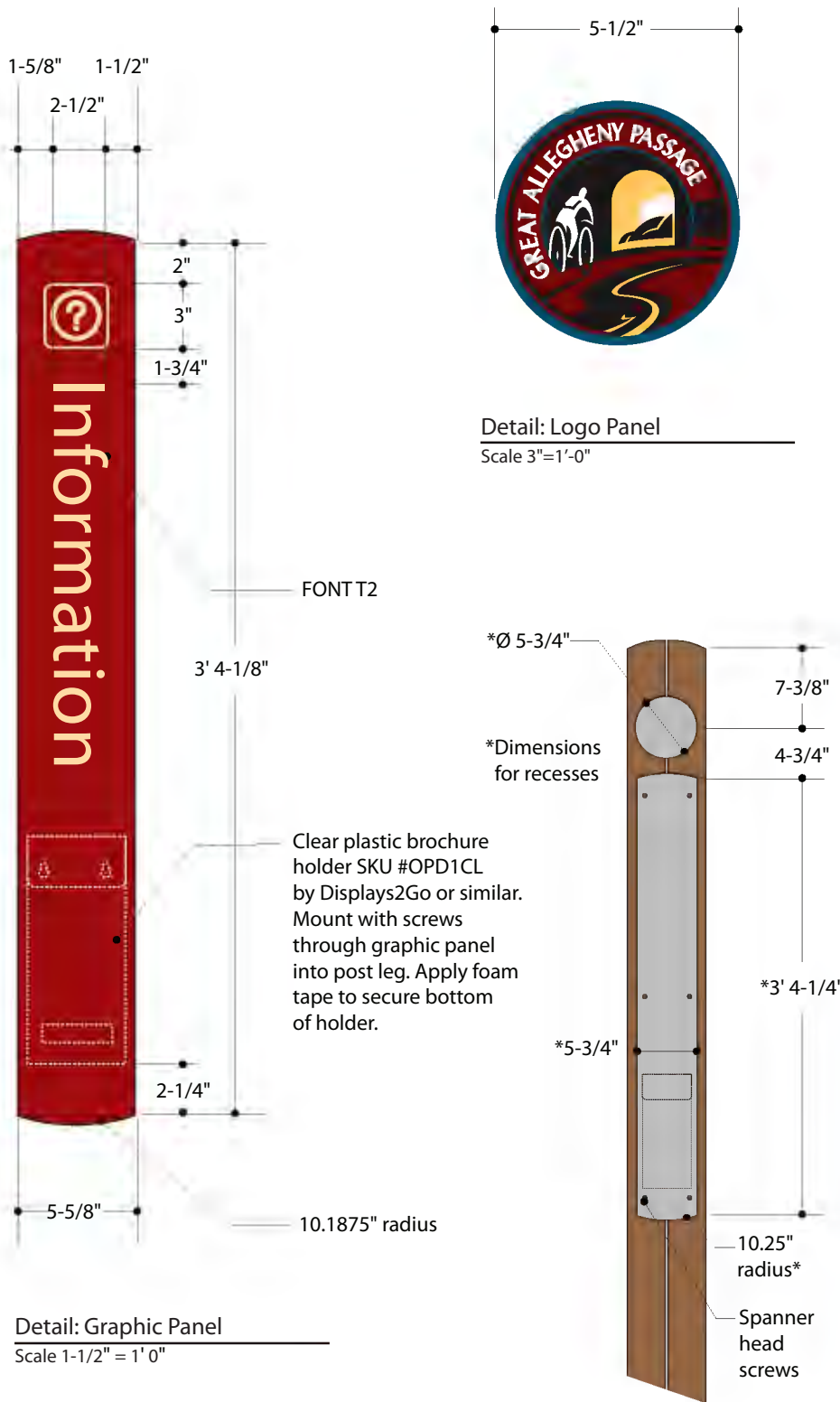

Detail: Logo Panel  
Scale 3"=1'-0"

Detail: Graphic Panel  
Scale 1-1/2" = 1' 0"

Detail: Post Layout with Panels  
Scale 3/4" = 1' 0"

### GENERAL NOTES

**1** Graphic and logo panels are 1/8" painted aluminum sheet with screen-printed graphics and are attached to plastic sign body with spanner head screws that are painted to match the graphic panel. See construction drawing for location of screws.

**2** Two or three sets of the graphic and logo panel are required for the complete sign. Messages do not vary from that shown.

**3** Colors for the graphic panel are shown below. Edges and back of graphic panel are painted same as face color. See also page 3.5, Colors, Finishes, and Materials, for complete specifications.

**4** Complete colors for the logo panel are shown on page 2.1, Logo Overview. The edges and back of the logo panel are painted to match the outermost color of the logo.

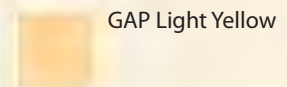
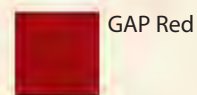

# INFORMATION KIOSKS

## Town Story Panel graphic specifications

### A2a

One of three standard kiosk panel types, the Town Story panel provides a glimpse of the history, culture, and perhaps commerce of the approaching town for trail users.

**1** Title header identifies the town and welcomes the trail user.

**2** Town identity stamps may be added to this space in the future.

**3** The body text gives historic context and identifies places of interest that trail users can see and visit today. Maximum length: 120-160 words.

**4** Town facts provide general, comparable context of trail towns.

**5** The background image shows regional scenery, the town skyline, or a historical image.

**6** Photos with snapshot-style frames show places of interest the trail users can visit today. They should relate to the body text. Photo sizes, position, and angle can vary.

**7** Photo captions can expand upon the main story. Maximum length: 32 words.

**8** "Green" design commitment statement from ATA/TTP.

Town Story panels are reproduced digitally in four colors (CMYK) on a vinyl adhesive applique. The applique is adhered to a metal substrate which is mounted to the kiosk post legs.

To ensure uniformity of your Town Story panel with others, please use the official graphic template file available from the Allegheny Trail Alliance or the Trail Town Program.

All typefaces are from the Myriad Pro family. See page 3.1 for details.

When selecting or taking photographs for your panel, be sure they have sufficient resolution. Images should be at least 150 dpi at their full size on the panel.

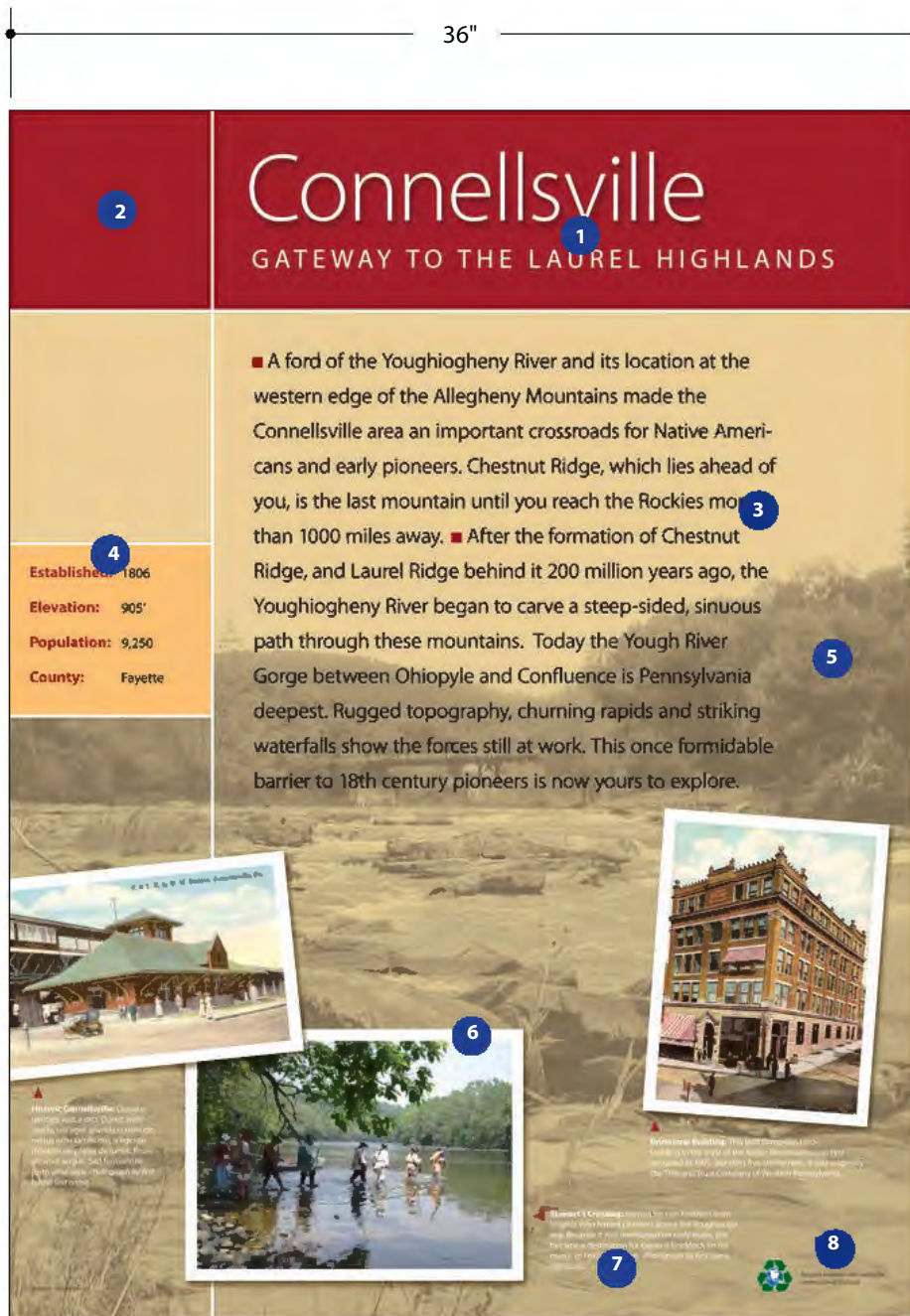

Detail: Typical Town Story Panel

Scale 1-1/2"=1' 0"



# INFORMATION KIOSKS

# A2b

## Town Map & Directory Panel graphic specifications

36"

**1** Title header identifies the town and sign function.

**2** The Trail Town Program logo conveys cachet of being part of a connected system of trail towns.

**3** Town map, with key numbers for shops, restaurants, services, and amenities.

**4** Directory of shops, restaurants, services, and amenities, keyed to map by number.

**5** Sponsor identification, optional.

**6** Photos with snapshot-style frames show a general skyline or main street image, or places of interest not specific to any business or service. Photo sizes, position, and angle can vary.

**7** Photo caption. Maximum length: 32 words.

48"

One of three standard kiosk panel types, the Town Map & Directory panel orients trail users to restaurants, shops, services, and amenities available in the trail town.

1 Title header identifies the town and sign function.

2 The Trail Town Program logo conveys cachet of being part of a connected system of trail towns.

3 Town map, with key numbers for shops, restaurants, services, and amenities.

4 Directory of shops, restaurants, services, and amenities, keyed to map by number.

5 Sponsor identification, optional.

6 Photos with snapshot-style frames show a general skyline or main street image, or places of interest not specific to any business or service. Photo sizes, position, and angle can vary.

7 Photo caption. Maximum length: 32 words.

Town Map & Directory panels are reproduced digitally in four colors (CMYK) on a vinyl adhesive applique. The applique is adhered to a metal substrate which is mounted to the kiosk post legs.

To ensure uniformity of your Town Map & Directory panel with others, please use the official graphic template file available from the Allegheny Trail Alliance or the Trail Town Program.

All typefaces are from the Myriad Pro family. See page 3.1 for details.

When selecting or taking photographs for your panel, be sure they have sufficient resolution. Images should be at least 150 dpi at their full size on the panel.

### Detail: Typical Town Map Panel

Scale 1-1/2"=1' 0"

# INFORMATION KIOSKS

## Trail Map Panel graphic specifications

A2c

One of three standard kiosk panel types, the Trail Map panel gives trail users valuable orientation information and highlights points of interest and changes in elevation.

1 Title header identifies the town and sign function.

2 The Great Allegheny Passage logo conveys cachet of being part of a greater trail system.

3 Sponsor identification, optional.

4 Photos with snapshot-style frames and special caption area show places of interest along the trail. Images can be cropped square or vertical. Vertical height of frame remains constant.

5 Map legend appears in same location on all Trail Map panels.

6 Standard descriptor and key map for Great Allegheny passage appears same on all Trail Map panels.

7 Trail region key map varies by location: Inset box moves to relate to map area and distance messages change.

8 Elevation chart remains constant, except for location of red dot indicating current position.

Trail Map panels are reproduced digitally in four colors (CMYK) on a vinyl adhesive applique. The applique is adhered to a metal substrate which is mounted to the kiosk post legs.

To ensure uniformity of your Trail Map panel with others, please use the official graphic template file available from the Allegheny Trail Alliance or the Trail Town Program.

All typefaces are from the Myriad Pro family. See page 3.1 for details.

When selecting or taking photographs for your panel, be sure they have sufficient resolution. Images should be at least 150 dpi at their full size on the panel.

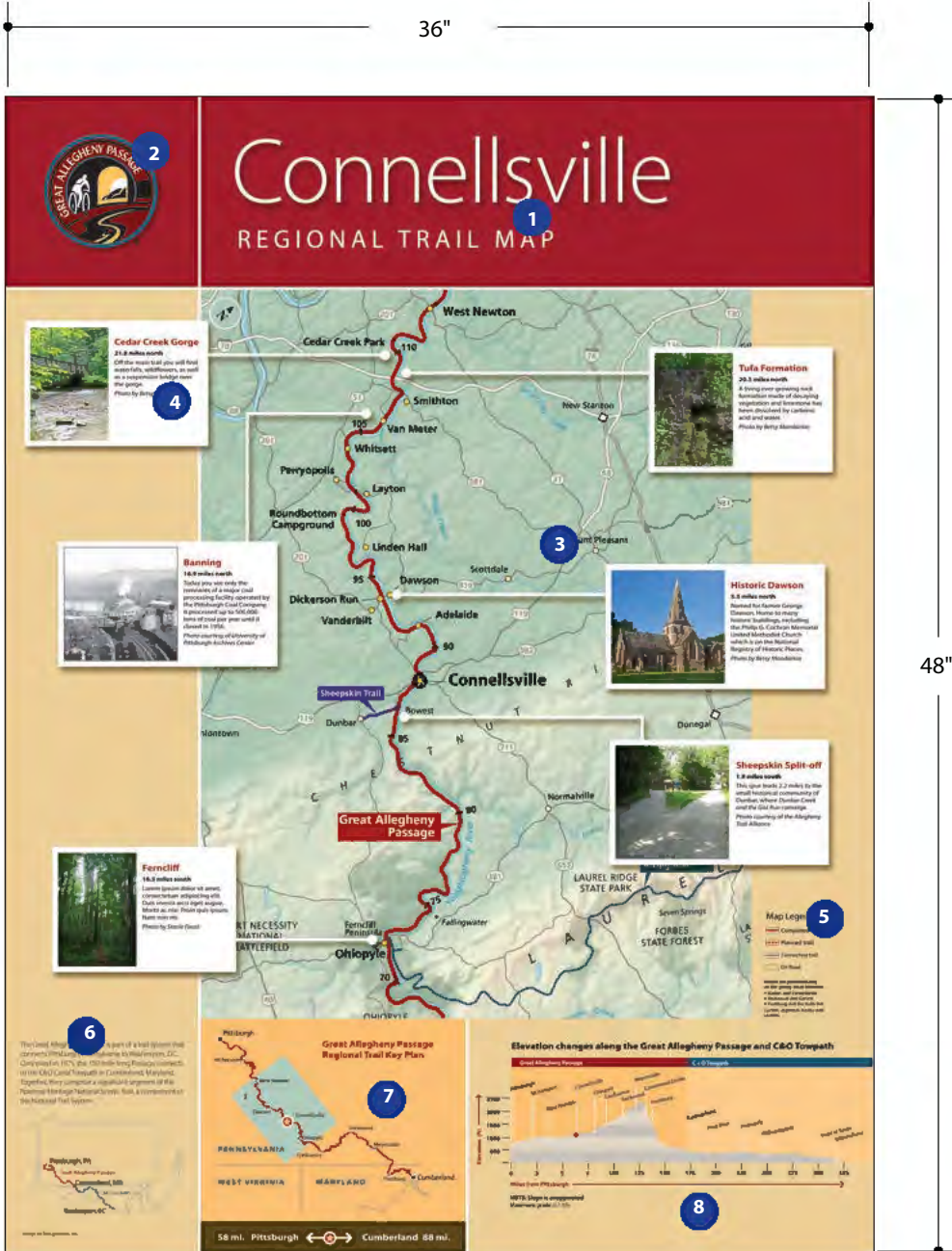

Detail: Typical Trail Map Panel

Scale 1-1/2"=1' 0"



This sign is typically located near the trail access points from parking lots. One side displays trail rules and suggestions for considerate trail use. The other side recognizes trail groups and funding organizations. The sign is situated so that its faces are perpendicular to the trail, with the trail rules and etiquette side facing the access path.

The Trail Rules & Etiquette sign example on the left shows placeholder text and suggested international symbols. The text for this sign is available from the Allegheny Trail Alliance. It may be amended to reflect the circumstances of your particular trail segment. Some or all of the symbols shown in the example may be applicable to your segment.

The Trail Support & Stewardship panel shows placeholder text similar to an existing sign from West Newton. Copy for any Trail Support & Stewardship panel should be approved by the Allegheny Trail Alliance. Identity logos for trail organizations are also subject to approval.

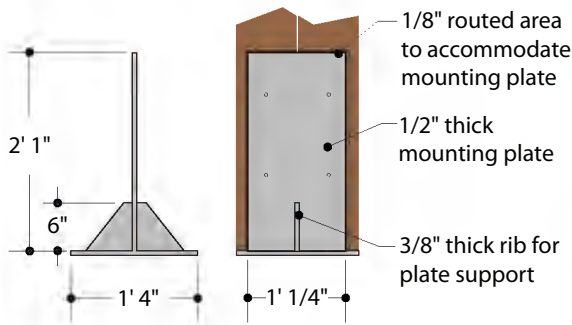

Footer Mounting Plate  
Not to Scale

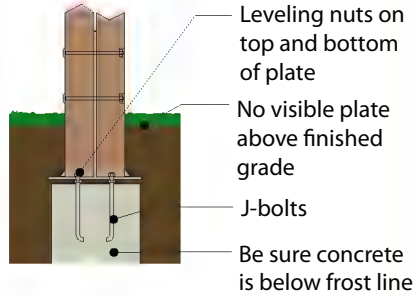

Footer Assembly  
Not to Scale

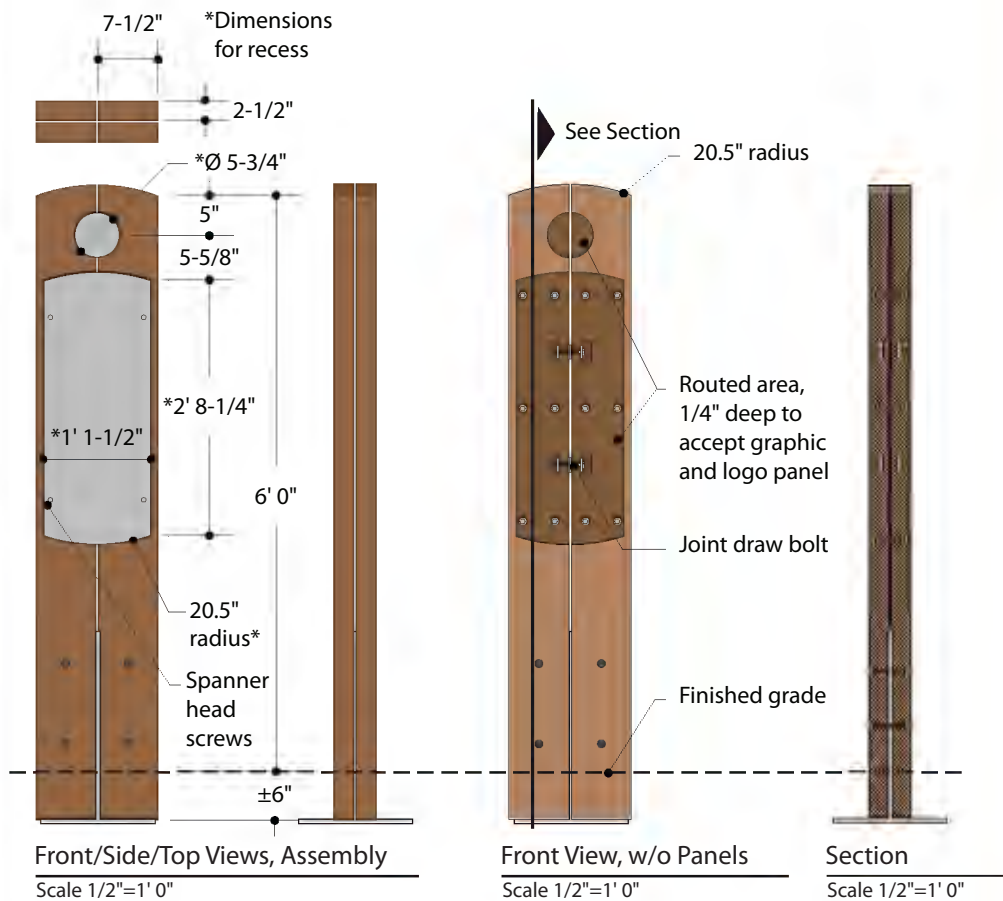

GENERAL NOTES

- 1 The body of this sign is made from 3"x8"x12' plastic lumber. Color/material: GAP Cedar.
- 2 The mounting plate is welded from steel plate. For corrosion protection, the plate must be galvanized.
- 3 The footer is recycled concrete poured in a round form such as Sono-tube, with J-bolts inserted. Be sure the footer passes below the frost line of the installation location.
- 4 The footer and mounting plate must be set low enough that the mounting plate rib is just under the finished grade and not exposed.
- 5 By placing nuts on the J-bolts under and above the mounting plate, the plate can be adjusted level and plumb. Nuts with nylon inserts are recommended.
- 6 Joint draw bolts, nuts, and bolts behind the graphic panels must be countersunk or recessed in the lumber so they do not obstruct the graphic panels.
- 7 Washers should be placed on all attachments between the boards to maintain consistent 1/4" spacing between all boards.
- 8 The inside faces of boards are routed to accommodate the mounting plate while maintaining 1/4" spacing between the boards.
- 9 The sign is secured to the mounting plate with carriage bolts. The nuts for these carriage bolts should be countersunk and the holes covered with a cap matching the carriage bolt heads.
- 10 The 1/4" recesses to receive the logo and graphic panels must be free of scalloping. There must be a smooth, consistent 1/8" gap all around the installed graphic panels.

Graphic specifications



Detail: Logo Panel

Scale 1-1/2"=1' 0"

LAYOUT NOTES

For body text of both panels, set "Space Before Paragraph" to 40 points.

Prohibitory symbols are 1-1/4" wide. See page 3.4 for specifications.

\*Text area can expand vertically if there is no logo below.

GENERAL NOTES

**1** Graphic and logo panels are 1/8" painted aluminum sheet with screen-printed graphics and are attached to plastic sign body with spanner head screws that are painted to match the graphic panel. See construction drawing for location of screws.

**2** Two logo panels and one of each graphic panel are required for the complete sign.

**3** Colors for the graphic panels are shown below. Edges and back of graphic panel are painted same as face color. See also page 3.5, Colors, Finishes, and Materials, for complete specifications.

**4** Complete colors for the logo panel are shown on page 2.1, Logo Overview. The edges and back of the logo panel are painted to match the outermost color of the logo.

**5** Messages outlined in dashed boxes may change. The dashed box indicates maximum extent of copy. Other messages should not change.

**6** Trail rules and etiquette may need to be individualized, based on trail section requirements. Trail Support & Stewardship message should be developed by the managing trail organization.

 GAP Red

 GAP Light Red

 GAP Light Yellow

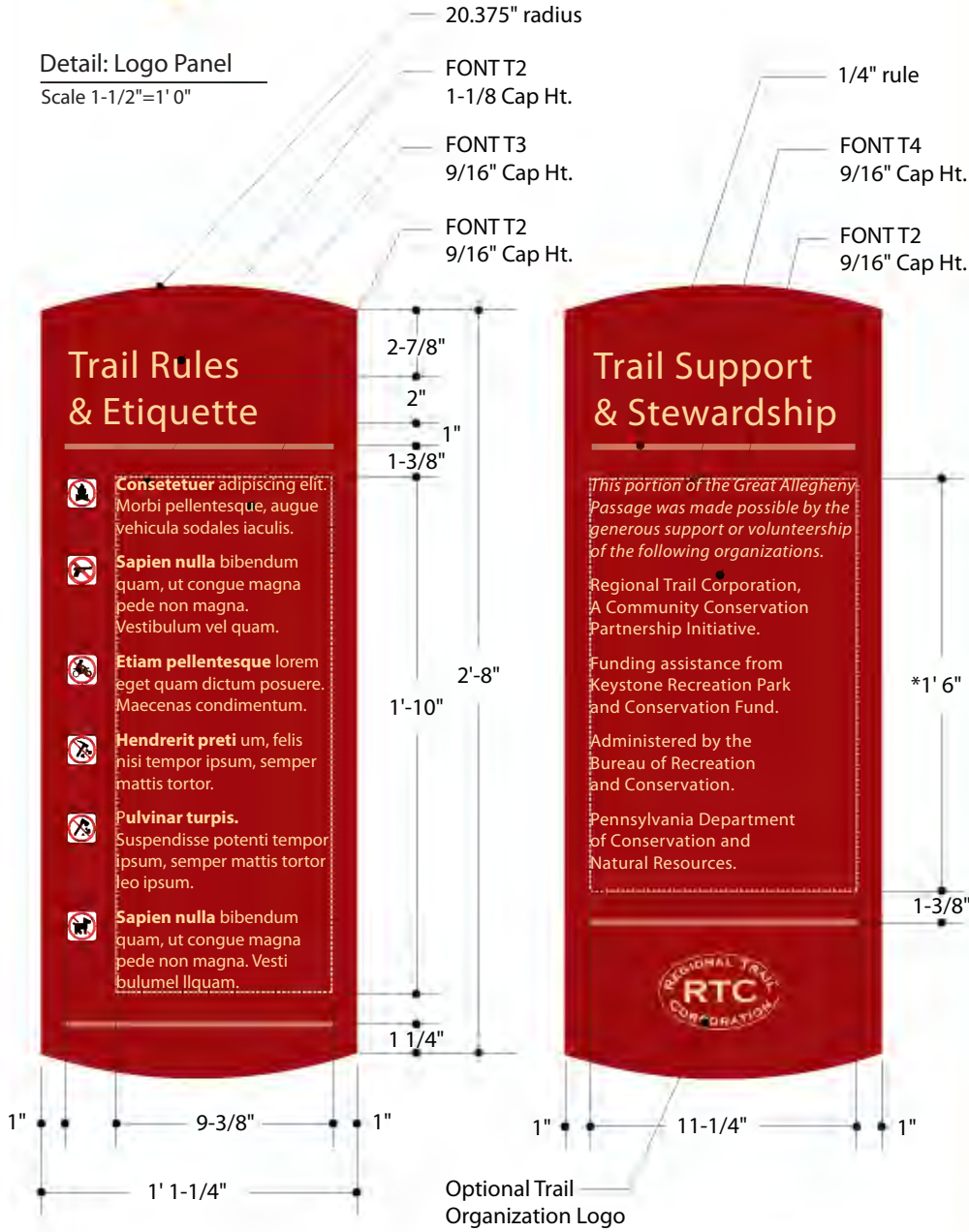

Detail: Graphic Panel 1

Scale 1-1/2"=1' 0"

Detail: Graphic Panel 2

Scale 1-1/2"=1' 0"

# DIRECTIONAL: TRAIL DESTINATIONS

T1

Overview



This sign is located on the trail opposite of and facing the access path from parking areas. The front of the sign shows all major trail towns listed in order from Pittsburgh to Cumberland, along with Washington—the latter in a subdued color. The user's current location in the sequence, not listed, is marked with a rule which thus divides destinations to the left and to the right.

The back of the sign, typically facing woods and not highly visible, can be dressed with a pattern. For component consistency among different sign types, all signs have back panels.

# DIRECTIONAL: TRAIL DESTINATIONS

## Construction

### T 1

#### GENERAL NOTES

- 1 The body of this sign is made from 3"x8"x12' plastic lumber. Color/material: GAP Cedar.
- 2 The mounting plate is welded from steel plate. For corrosion protection, the plate must be galvanized.
- 3 The footer is recycled concrete poured in a round form such as Sono-tube, with J-bolts inserted. Be sure the footer passes below the frost line of the installation location.

- 4 The footer and mounting plate must be set low enough that the mounting plate rib is just under the finished grade and not exposed.

- 5 By placing nuts on the J-bolts under and above the mounting plate, the plate can be adjusted level and plumb. Nuts with nylon inserts are recommended.

- 6 Joint draw bolts, nuts, and bolts behind the graphic panels must be countersunk or recessed in the lumber so they do not obstruct the graphic panels.

- 7 Washers should be placed on all attachments between the boards to maintain consistent 1/4" spacing between all boards.

- 8 The inside faces of boards are routed to accommodate the mounting plate while maintaining 1/4" spacing between the boards.

- 9 The sign is secured to the mounting plate with carriage bolts. The nuts for these carriage bolts should be countersunk and the holes covered with a cap matching the carriage bolt heads.

- 10 The 1/4" recesses to receive the logo and graphic panels must be free of scalloping. There must be a smooth, consistent 1/8" gap all around the installed graphic panels.

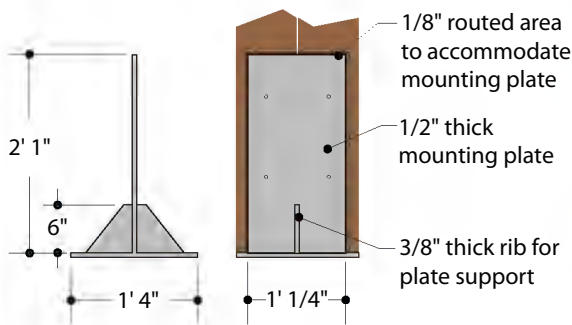

Footer Mounting Plate

Not to Scale

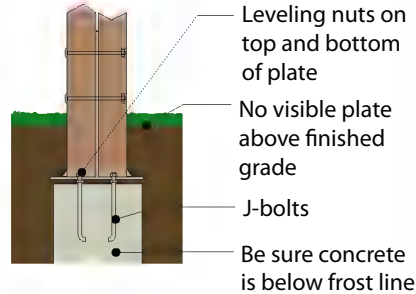

Footer Assembly

Not to Scale

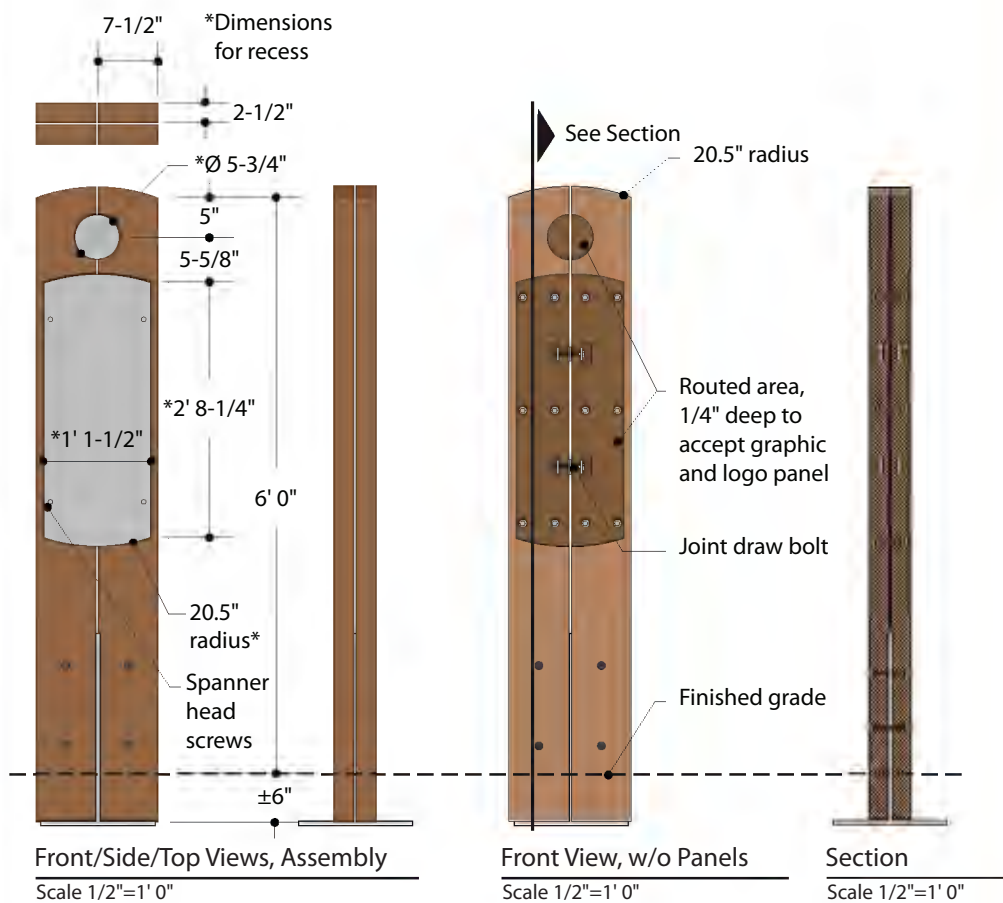

Front/Side/Top Views, Assembly

Scale 1/2"=1' 0"

Front View, w/o Panels

Scale 1/2"=1' 0"

Section

Scale 1/2"=1' 0"

# DIRECTIONAL: TRAIL DESTINATIONS

## Graphic specifications

T 1



Detail: Logo Panel

Scale 1-1/2"=1' 0"

### LAYOUT NOTES

Position of rule and arrows vary by location; they are positioned to correspond with the user's location in the sequence of towns.

Only the town names shown in the typical layout, plus Connellsville, should be included in this sign type.

Names of next towns to north and south are bolded, but mileage remains regular.

### GENERAL NOTES

**1** Graphic and logo panels are 1/8" painted aluminum sheet with screen-printed graphics and are attached to plastic sign body with spanner head screws that are painted to match the graphic panel. See construction drawing for location of screws.

**2** Two logo panels and one of each graphic panel are required for the complete sign.

**3** Colors for the graphic panels are shown below. Edges and back of graphic panel are painted same as face color. See also page 3.5, Colors, Finishes, and Materials, for complete specifications.

**4** Complete colors for the logo panel are shown on page 2.1, Logo Overview. The edges and back of the logo panel are painted to match the outermost color of the logo.

**5** Messages outlined in dashed boxes may change. The dashed box indicates maximum extent of copy. Other messages should not change.

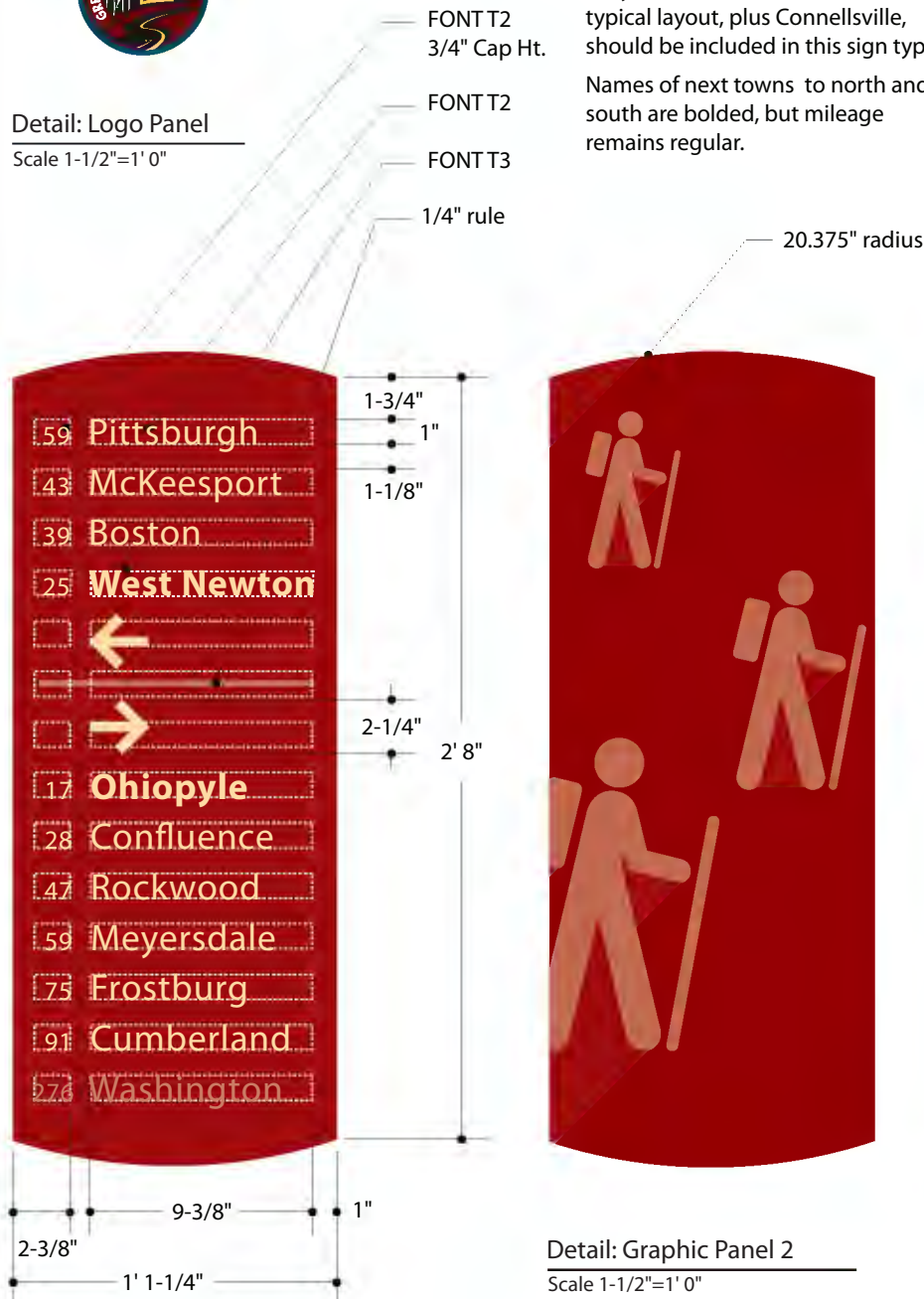

Detail: Graphic Panel 1

Scale 1-1/2"=1' 0"

Detail: Graphic Panel 2

Scale 1-1/2"=1' 0"







Trail Directional Amenity signs are located at road crossings, to broadly orient trail users to the trail towns they are approaching. The front of the sign displays directional messages in two or three groupings: Destinations ahead, destinations to the left, and destinations to the right.

The written messages must be very broad, providing only general geographic cues (Downtown, Southside, Main Street, State Route 25) or resources and destinations of special value to the user (Visitor Center, Fallingwater). Only one text line is allotted for this message in the standard format. Any exception will require limiting information elsewhere in the layout. Specific restaurants or stores should not be signed. This more detailed information is available at Information Kiosks—See page 5.4.

Up to three international symbols on one line can be included with each directional grouping to orient trail users to general direction of services and amenities in town (food, telephone, restrooms, etc). See page 3.6 for more international symbols available for this purpose.

The topmost grouping, for destinations ahead, may include upcoming features of the trailhead (Visitor Center, Logo Cabin ) and always includes the next trail town and terminus town with mileage.

Two slender graphic panels on the sides of the sign include the same message: The name of the trail town and the name of the intersecting roadway.

The back of the sign, typically facing the roadway can be dressed with a pattern. For component consistency among different sign types, all signs have back panels.

# DIRECTIONAL: TOWN AMENITIES

## Construction

### T2

#### GENERAL NOTES

- 1** The body of this sign is made from 3"x8"x8' plastic lumber. Color/material: GAP Cedar.
- 2** The mounting plate is welded from steel plate. For corrosion protection, the plate must be galvanized.
- 3** The footer is recycled concrete poured in a round form such as Sono-tube, with J-bolts inserted. Be sure the footer passes below the frost line of the installation location.
- 4** The footer and mounting plate must be set low enough that the mounting plate rib is just under the finished grade and not exposed.
- 5** By placing nuts on the J-bolts under and above the mounting plate, the plate can be adjusted level and plumb. Nuts with nylon inserts are recommended.
- 6** Joint draw bolts, nuts, and bolts behind the graphic panels must be countersunk or recessed in the lumber so they do not obstruct the graphic panels.
- 7** Washers should be placed on all attachments between the boards to maintain consistent 1/4" spacing between all boards.
- 8** The inside faces of boards are routed to accommodate the mounting plate while maintaining 1/4" spacing between the boards.
- 9** The sign is secured to the mounting plate with carriage bolts. The nuts for these carriage bolts should be countersunk and the holes covered with a cap matching the carriage bolt heads.
- 10** The 1/4" recesses to receive the logo and graphic panels must be free of scalloping. There must be a smooth, consistent 1/8" gap all around the installed graphic panels.

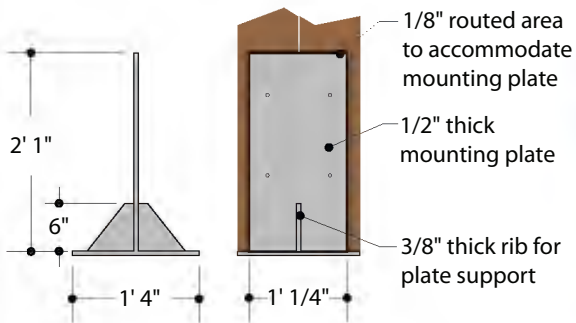

**Footer Mounting Plate**  
Not to Scale

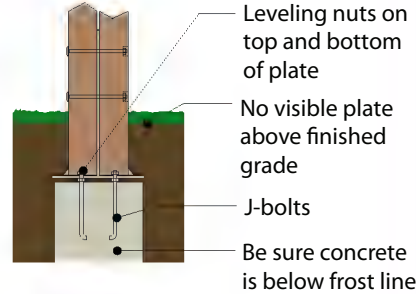

**Footer Assembly**  
Not to Scale

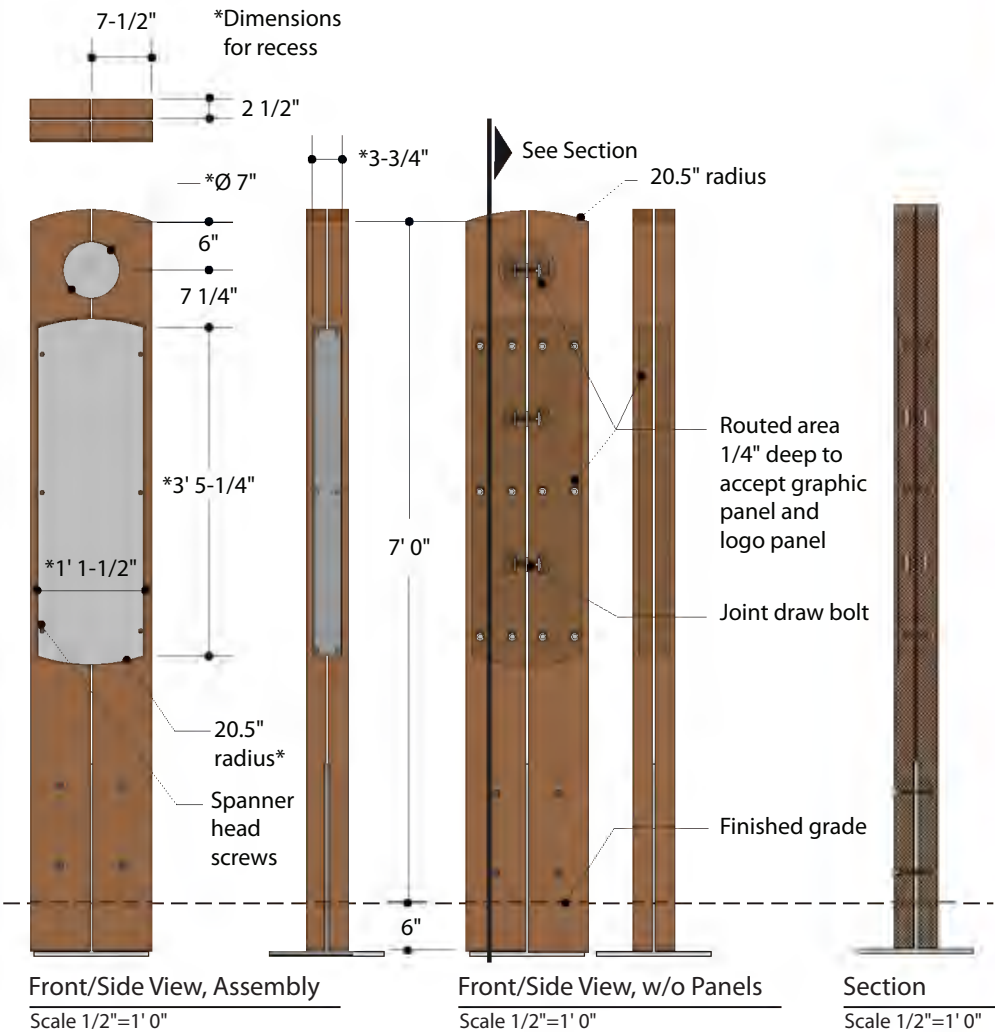

**Front/Side View, Assembly**  
Scale 1/2"=1' 0"

**Front/Side View, w/o Panels**  
Scale 1/2"=1' 0"

**Section**  
Scale 1/2"=1' 0"

# DIRECTIONAL: TOWN AMENITIES

## Graphic specifications

T2

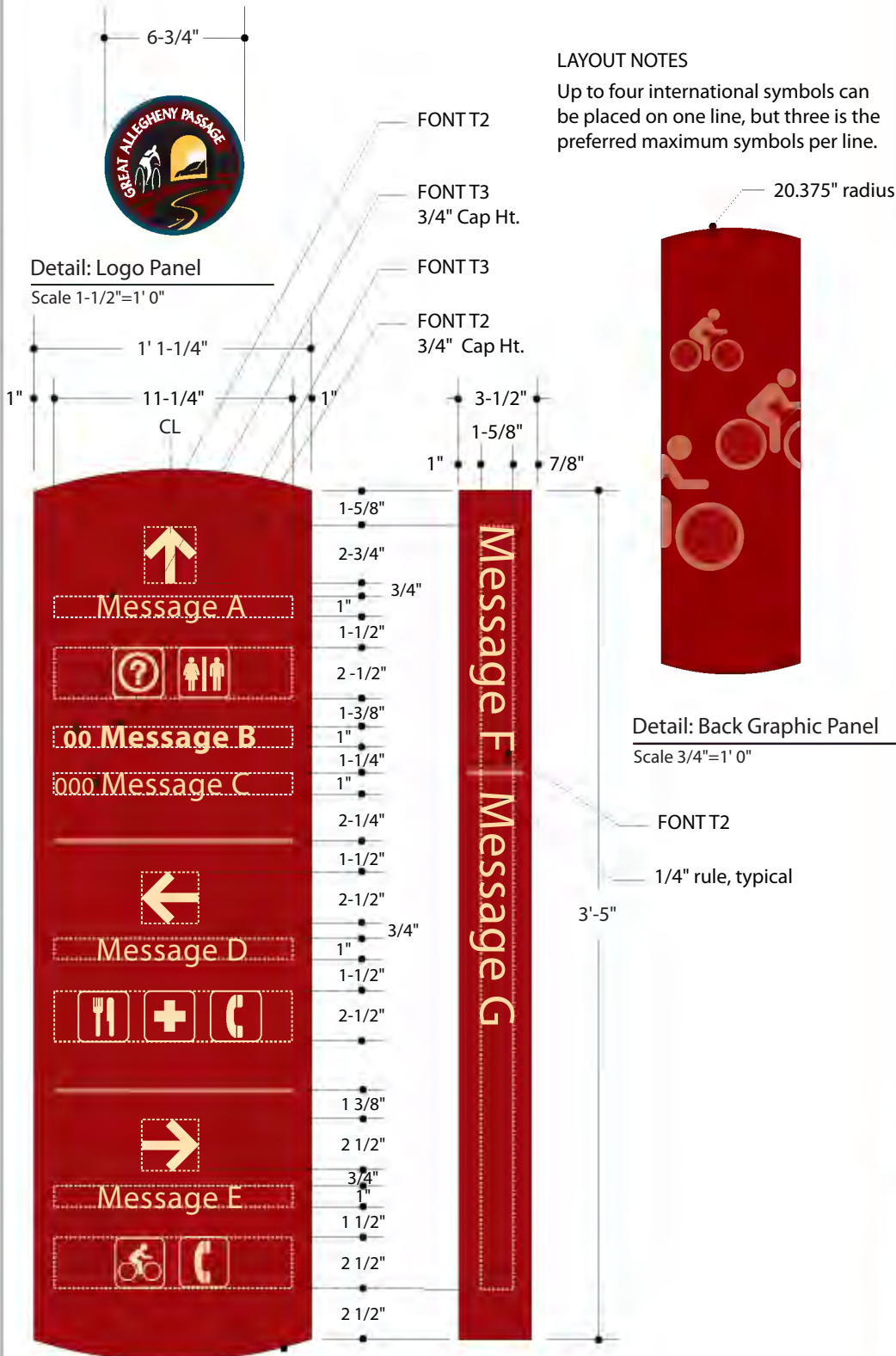

### LAYOUT NOTES

Up to four international symbols can be placed on one line, but three is the preferred maximum symbols per line.

### GENERAL NOTES

**1** Graphic and logo panels are 1/8" painted aluminum sheet with screen-printed graphics and are attached to plastic sign body with spanner head screws that are painted to match the graphic panel. See construction drawing for location of screws.

**2** Two logo panels, two identical side panels, and one of each remaining graphic panel are required for the complete sign.

**3** Colors for the graphic panels are shown below. Edges and back of graphic panel are painted same as face color. See also page 3.5, Colors, Finishes, and Materials, for complete specifications.

**4** Complete colors for the logo panel are shown on page 2.1, Logo Overview. The edges and back of the logo panel are painted to match the outermost color of the logo.

**5** Messages outlined in dashed boxes will vary from location to location. The dashed box indicates maximum extent of copy.



# SPECIAL FEATURE IDENTIFIER

T3

## Overview



Brush Tunnel

Size A: 9–12 Characters



↑ Fallingwater

Size B: 12–15 Characters



Salisbury Viaduct

Size C: 15–18 Characters



Pinkerton High Bridge

Size D: 18–21 Characters

### Standard Sign Examples

Special feature identifiers are smaller horizontal signs that identify scenic and historical sites of interest along the trail. They are single-sided and come in four standard lengths to accommodate a variety of place names, but custom lengths can be created as well for longer messages—just use multiples of four inches.

Usually, the sign type acts as an identifier of something that is immediately visible. Less frequently, it may include an arrow to lead to a destination removed from the trail.

Depending on the mounting condition, these signs are mounted with thru-bolts and nuts, with bolts set in epoxy, or with lag bolts.

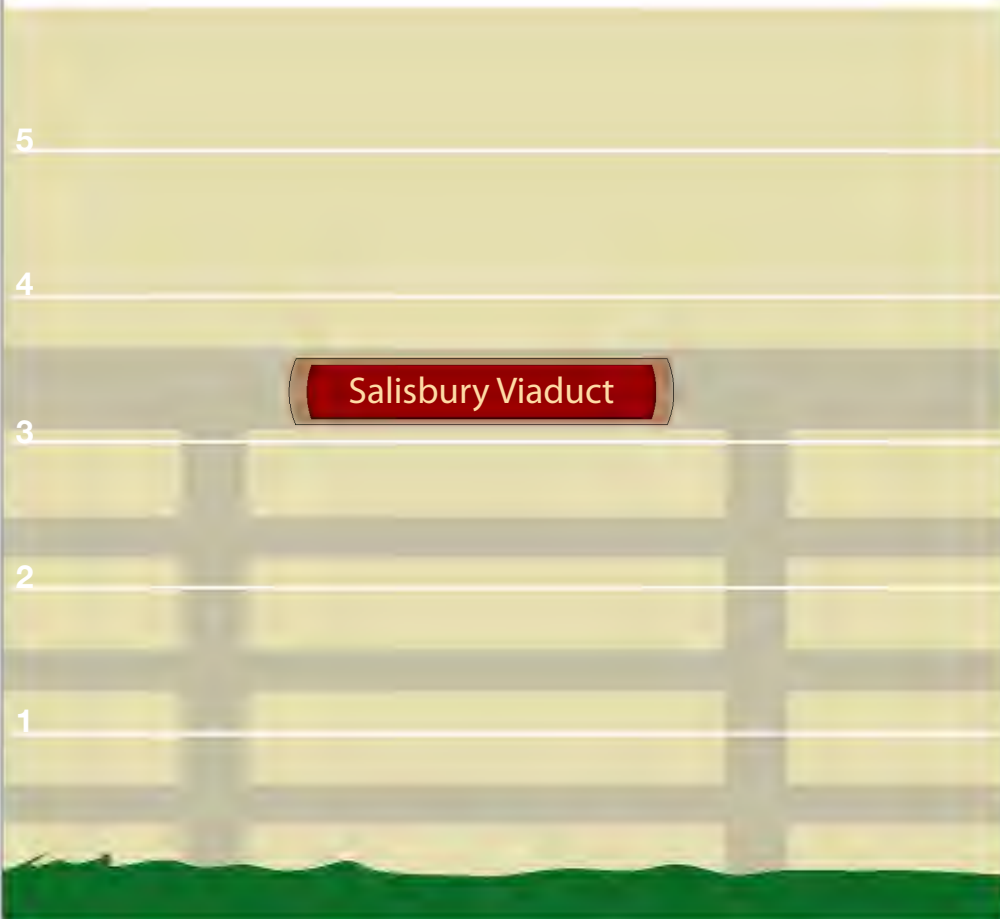

# SPECIAL FEATURE IDENTIFIER

# T3

## Construction

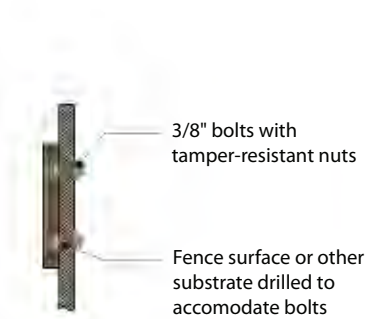

Section, Mounting Detail 1  
Scale 1-1/2"=1' 0"

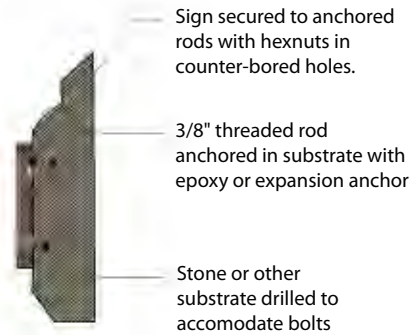

Section, Mounting Detail 2  
Scale 1-1/2"=1' 0"

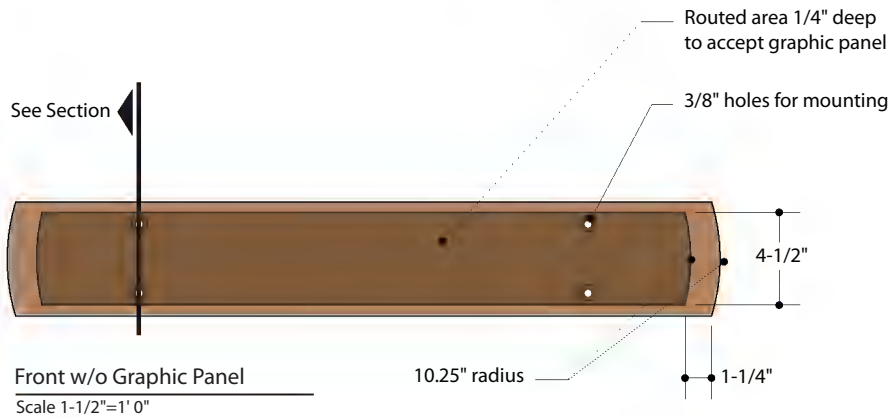

Front w/o Graphic Panel  
Scale 1-1/2"=1' 0"

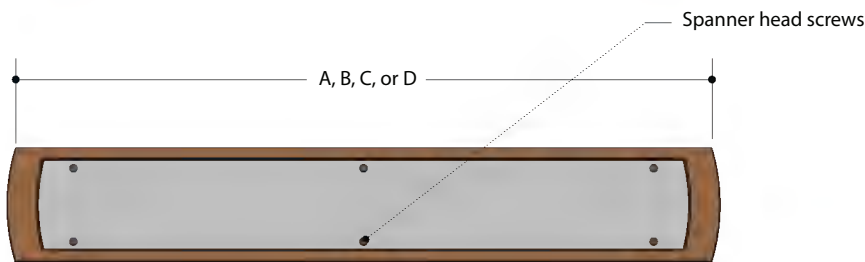

Front View, Assembly  
Scale 1-1/2"=1' 0"

### STANDARD BOARD LENGTHS

- A = 1' 10"
- B = 2' 2"
- C = 2' 6"
- D = 2' 10"

### GENERAL NOTES

- 1** The body of these signs are made from 5/4"x6" plastic lumber. Color/material: GAP Cedar.
- 2** When routing or milling the 1/4" recesses to receive the graphic panel, avoid scalloping the recess edges. There should be a smooth, consistent 1/16" gap all around the installed graphic panel.
- 3** Where signs are attached to fence rails or other substrates with backside access, they are attached with thru-bolts and tamper-resistant hexnuts. The bolt head should be countersunk below the surface of the recess to accommodate the graphic panel.
- 4** For mounting to rocks or masonry structures without access to backside, use lag bolts or threaded inserts anchored with epoxy.

# SPECIAL FEATURE IDENTIFIER

T3

## Graphic specifications

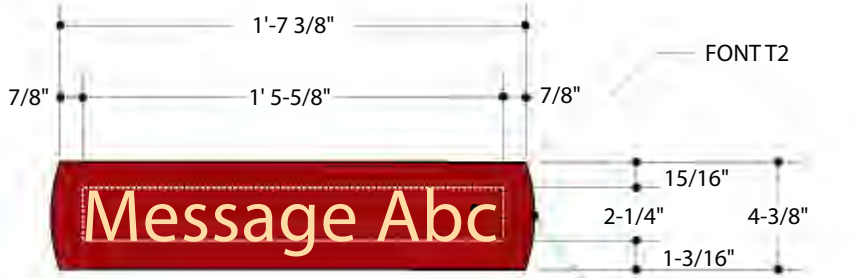

Size A: 9–12 Characters

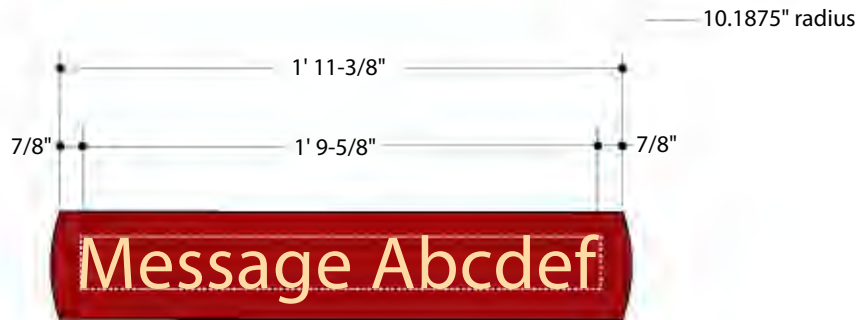

Size B: 12–15 Characters

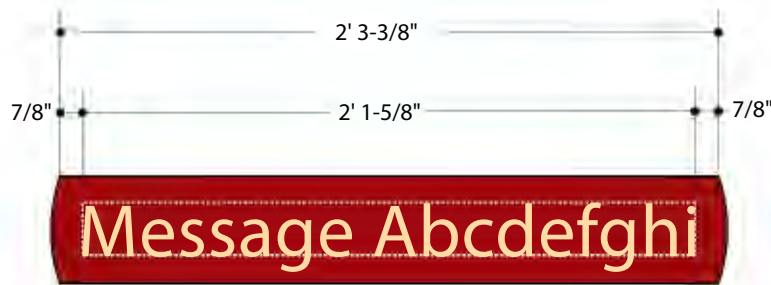

Size C: 15–18 Characters

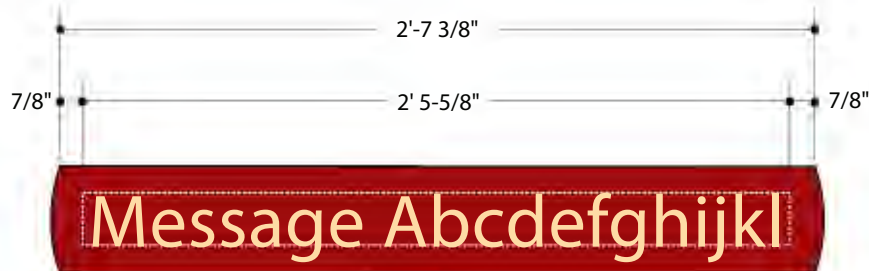

Size D: 18–21 Characters

### GENERAL NOTES

**1** Graphic panels are 1/8" painted aluminum sheet with screen-printed graphics and are attached to plastic sign body with spanner head screws that are painted to match the graphic panel. See construction drawing for location of screws.

**2** One graphic panel is required for each complete unit.

**3** Colors for the graphic panels are shown below. Edges and back of graphic panel are painted same as face color. See also page 3.5, Colors, Finishes, and Materials, for complete specifications.

**4** The dashed box indicates maximum extent of lettering, which will vary by location.

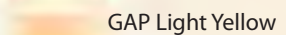
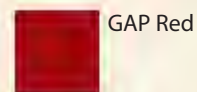

### Standard Graphic Panels

Scale 1-1/2"=1'-0"

## SPECIAL FEATURES POST SIGN

T4

### Overview

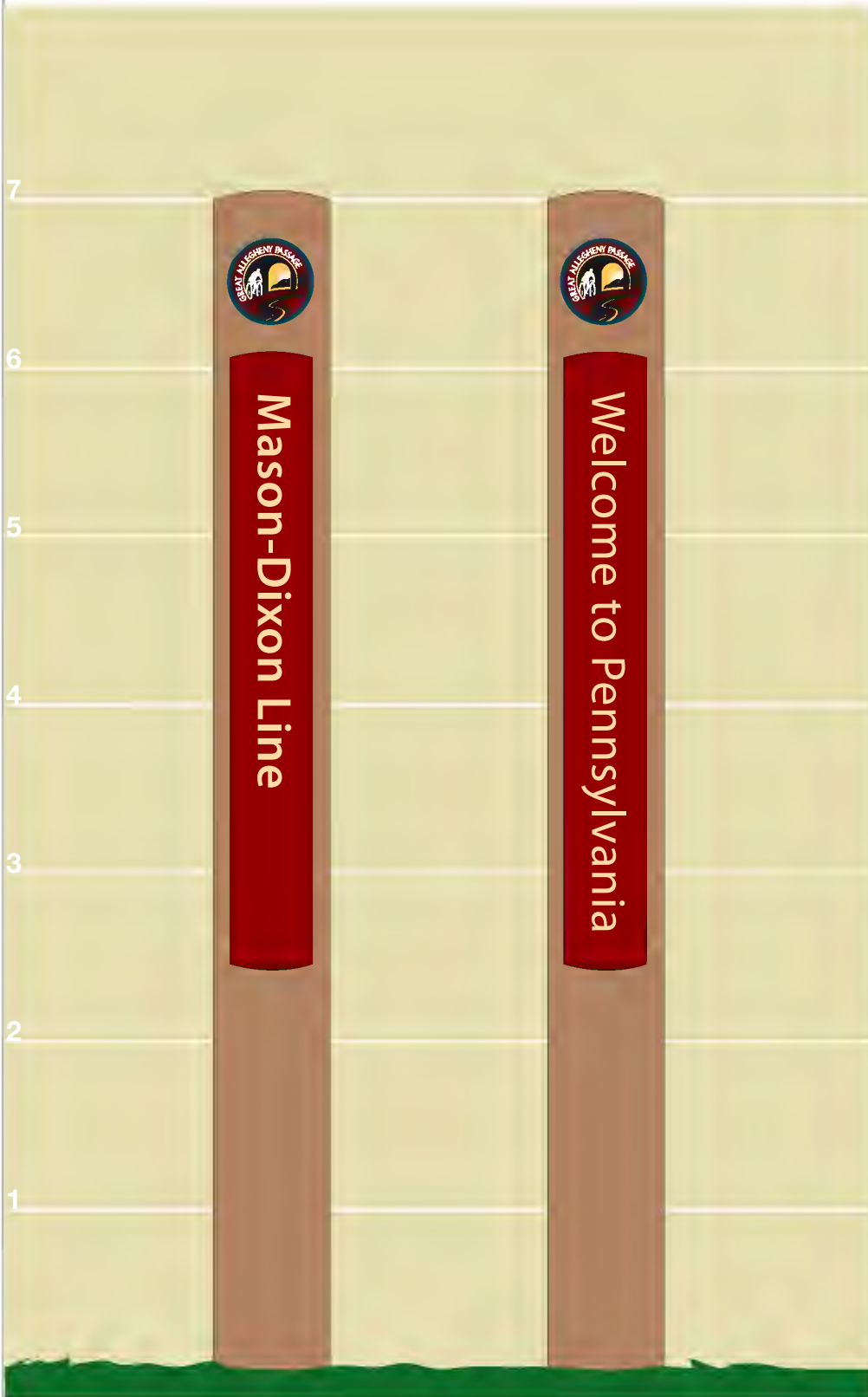

Some sites or features along the Great Allegheny Passage warrant special and distinctive signing.

This post design for identifying the Mason-Dixon line is intended to be installed in a pair flanking the trail, with the posts situated at a 45 degree angle to the trail. Thus, Mason-Dixon and Pennsylvania messages will be visible to north-bound trail users, and Mason-Dixon and Maryland messages will be visible to south-bound users.

This post design might be applied to other trail features as well.

Note that this sign is composed of only one solid piece of lumber, to distinguish it from the standard signs which are composed of four boards.

# SPECIAL FEATURES POST SIGN

T4

## Construction

### GENERAL NOTES

- 1 The body of this sign is made from 8"x8"x8' plastic lumber. Color/material: GAP Cedar.
- 2 The mounting plate is welded from steel plate. For corrosion protection, the plate must be galvanized.
- 3 The footer is recycled concrete poured in a round form such as Sono-tube, with J-bolts inserted. Be sure the footer passes below the frost line of the installation location.
- 4 The footer and mounting plate must be set low enough that the mounting plate rib is just under the finished grade and not exposed.
- 5 By placing nuts on the J-bolts under and above the mounting plate, the plate can be adjusted level and plumb. Nuts with nylon inserts are recommended.
- 6 The sign is slotted at the bottom in two directions to accept the mounting plate.
- 7 The sign post is secured to the mounting plate with carriage bolts. The nuts for these carriage bolts should be countersunk and the holes covered with a cap matching the carriage bolt heads.
- 8 The 1/4" recesses to receive the logo and graphic panels must be free of scalloping. There must be a smooth, consistent 1/8" gap all around the installed graphic panels.

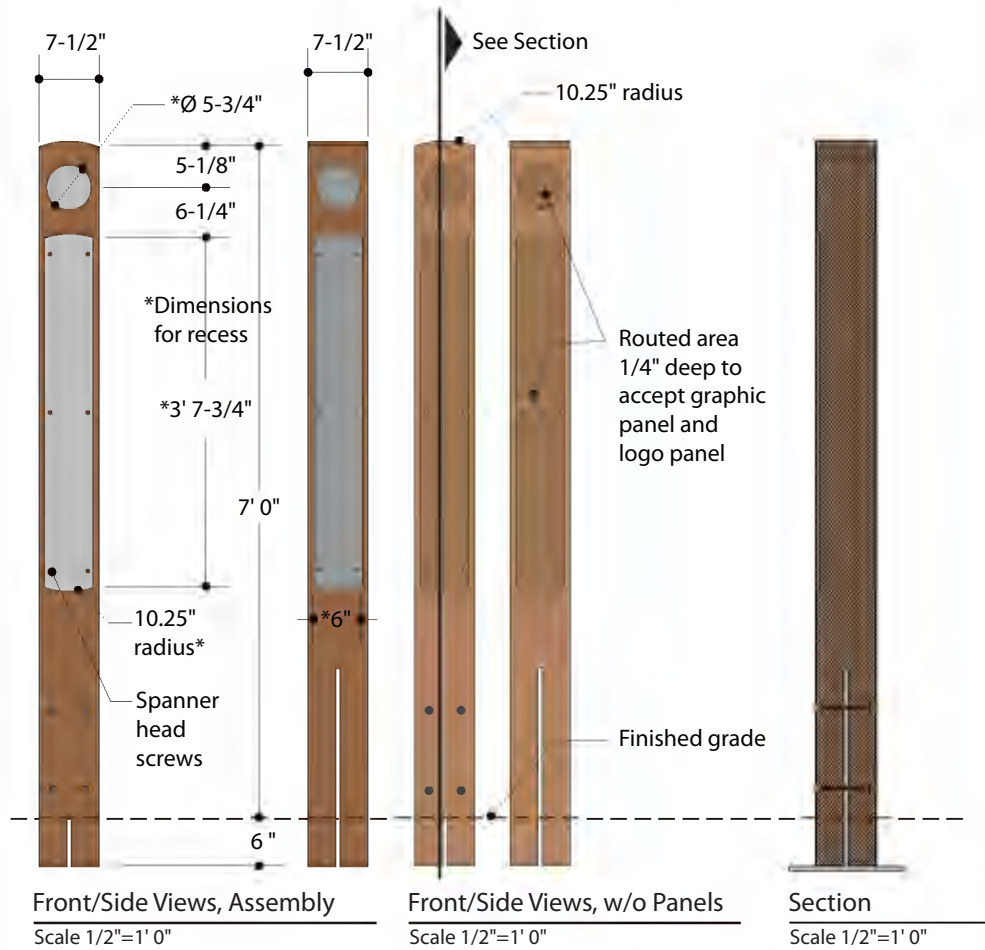
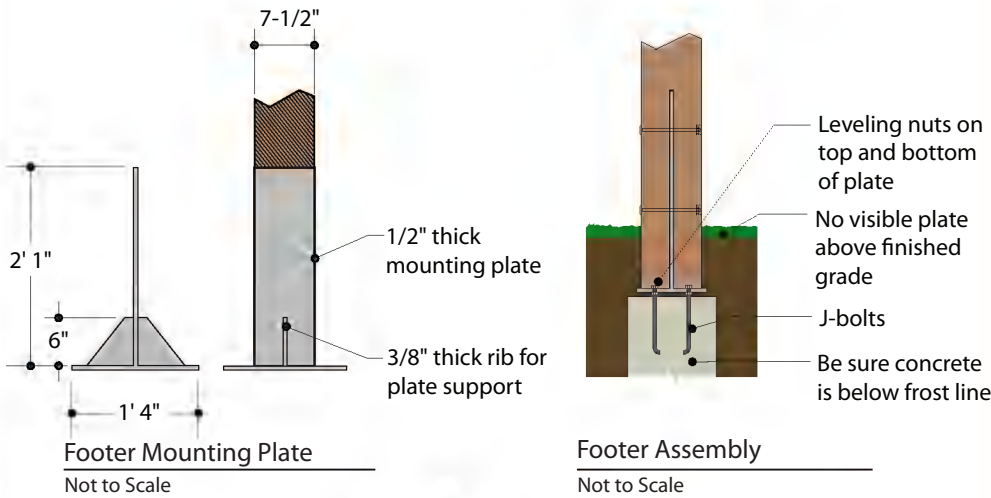



# SPECIAL FEATURES POST SIGN

T4

Graphic specifications

## GENERAL NOTES

**1** Graphic and logo panels are 1/8" painted aluminum sheet with screen-printed graphics and are attached to plastic sign body with spanner head screws that are painted to match the graphic panel. See construction drawing for location of screws.

**2** Four logo panels and four graphic panels are required for the complete sign.

**3** For the example shown, two panels signing Mason-Dixon Line are required—they are applied to opposing faces of the post. The remaining graphic panel appears on one face while another twin panel signing Welcome to Maryland (not shown) appears on the opposing face.

**4** Colors for the graphic panels are shown below. Edges and back of graphic panel are painted same as face color. See also page 3.5, Colors, Finishes, and Materials, for complete specifications.

**5** Complete colors for the logo panel are shown on page 2.1, Logo Overview. The edges and back of the logo panel are painted to match the outermost color of the logo.

**6** Messages outlined in dashed boxes will vary from location to location. The dashed box indicates maximum extent of lettering.

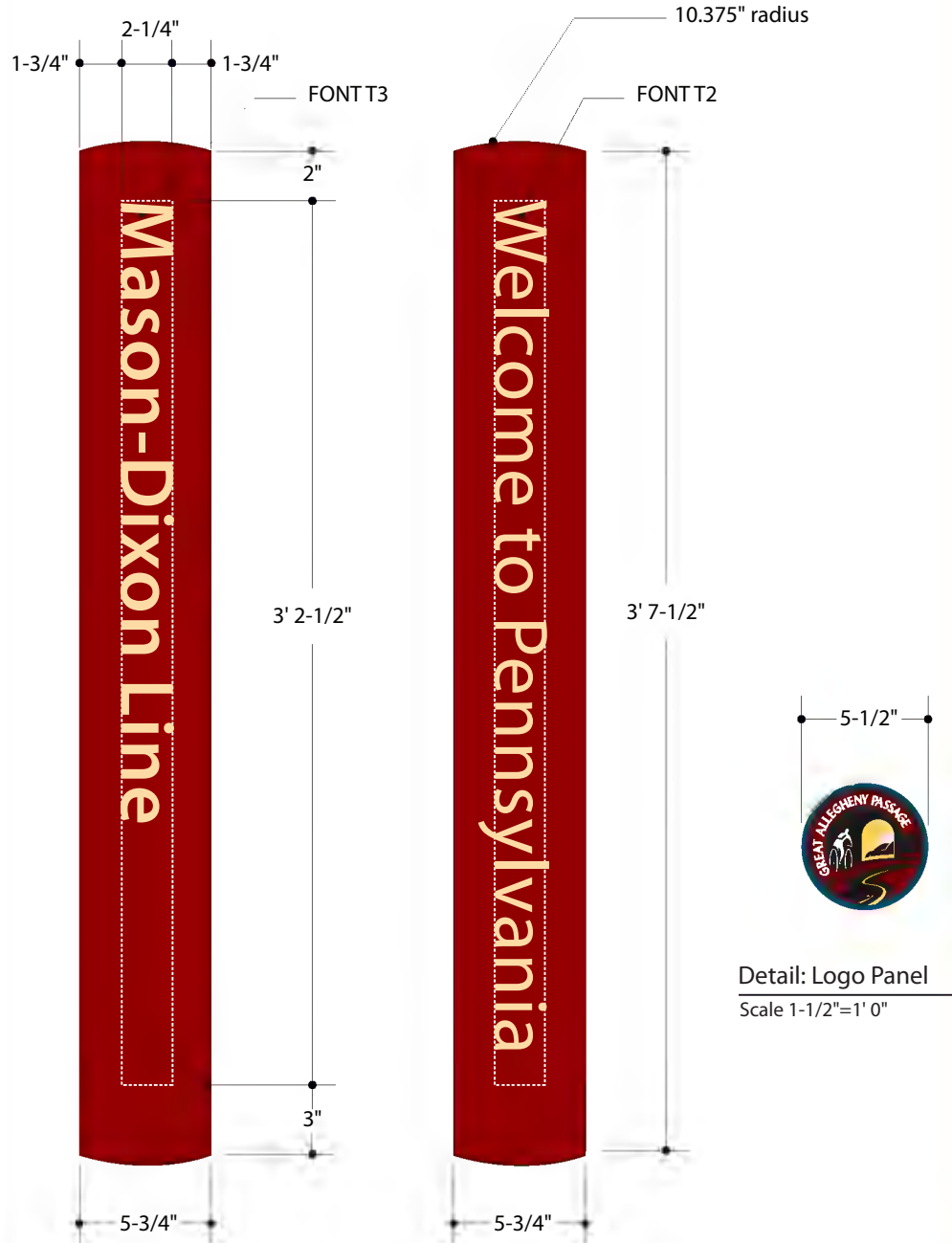

Detail: Graphic Panel 1

Scale 1 1/2"=1'-0"

Detail: Graphic Panel 2

Scale 1 1/2"=1'-0"

Detail: Logo Panel

Scale 1-1/2"=1' 0"

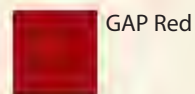

GAP Red

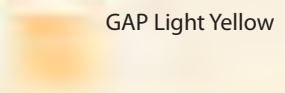

GAP Light Yellow

# MILE MARKER T5

## Overview

Mile markers resembling the drawing have been installed along most of the 150-mile trail system. In the short term, new or replacement markers should match the specifications on the following pages.

The mile markers are made of a flexible plastic extrusion by Carsonite. The material is designed just for this type of application, where the flexible plastic offers longevity in the face of much physical stress such as being hit by lawn mowers.

In the future, new mile markers may be redesigned to reflect the color and design motifs of the new sign family.

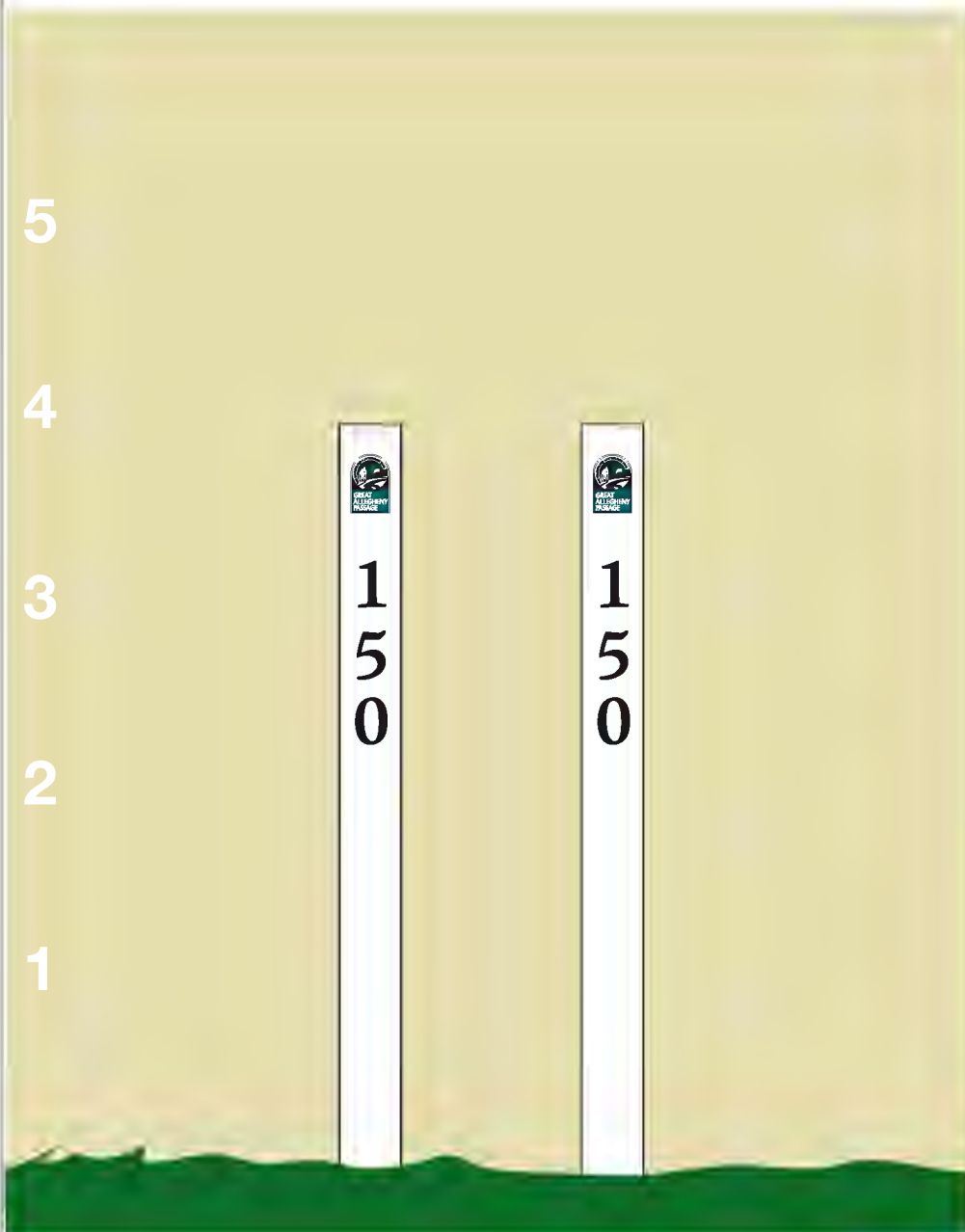

# MILE MARKER T5

## Construction and graphic specifications

Standard extrusion by Carsonite

No footer; Marker is driven into ground

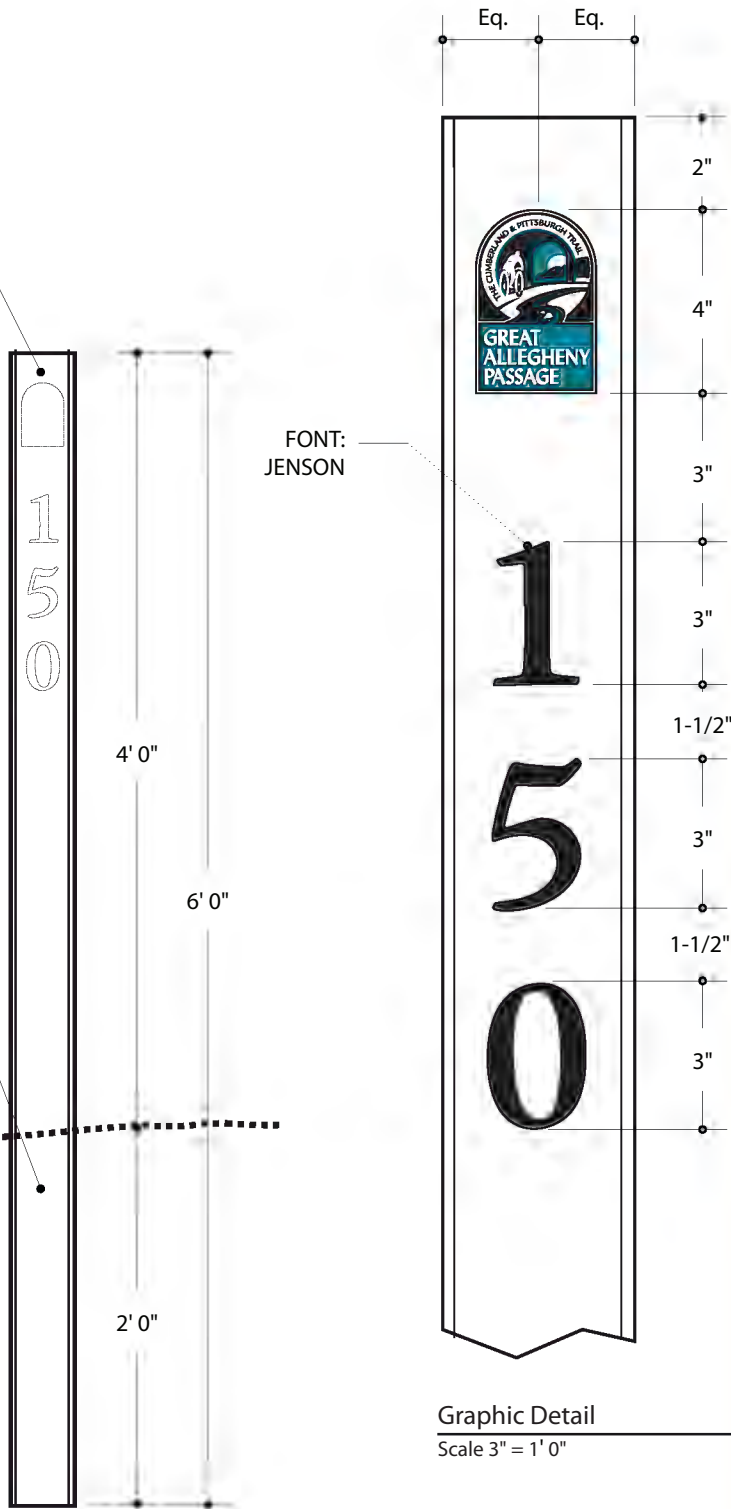

Mile markers are constructed of standard plastic extrusions in white, available from [www.carsonite.com](http://www.carsonite.com).

No footer is required. The markers are driven into the ground with a device available from the Allegheny Trail Alliance.

Graphics include numerals applied in black vinyl, and a two-color-on-white adhesive sticker for the logo. Graphics are identical on both sides of the marker.

Graphic Detail  
Scale 3" = 1' 0"

Sign Detail  
Scale 1" = 1' 0"

# TRAIL BLAZER T6

## Overview

Trail Blazer signs are typically located in urban areas where the trail may change course repeatedly or share the path of a road or pedestrian walkway. The sign should be located at decision points and intervals in between if distances are significant.

The layout shown represents an enhanced version of trail blazer signs currently in place: The post is painted GAP red and the sign panel includes a 2-color logo. The sign panel can be ordered from [www.buildasign.com](http://www.buildasign.com).

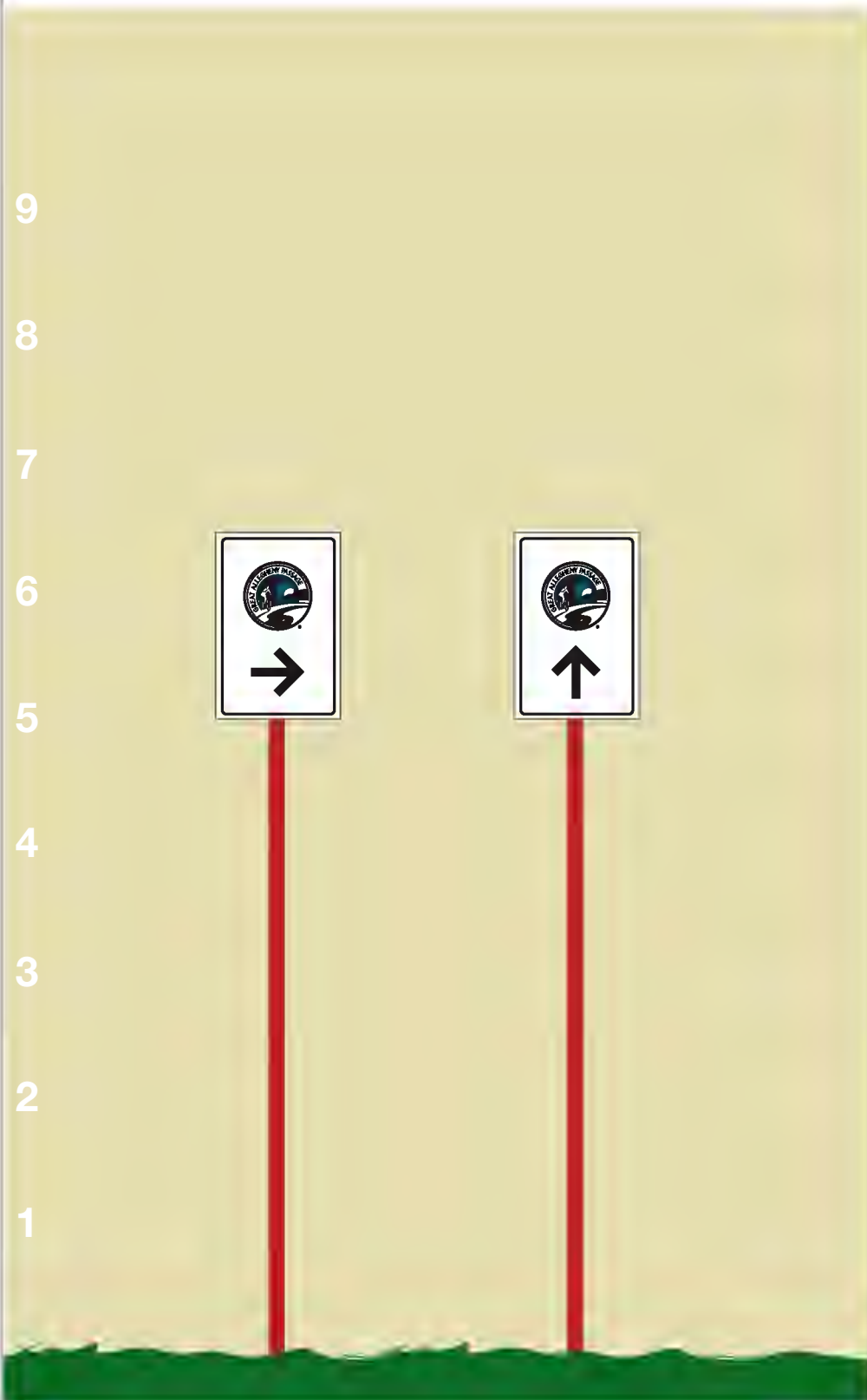

# TRAIL BLAZER

## Construction

# T6

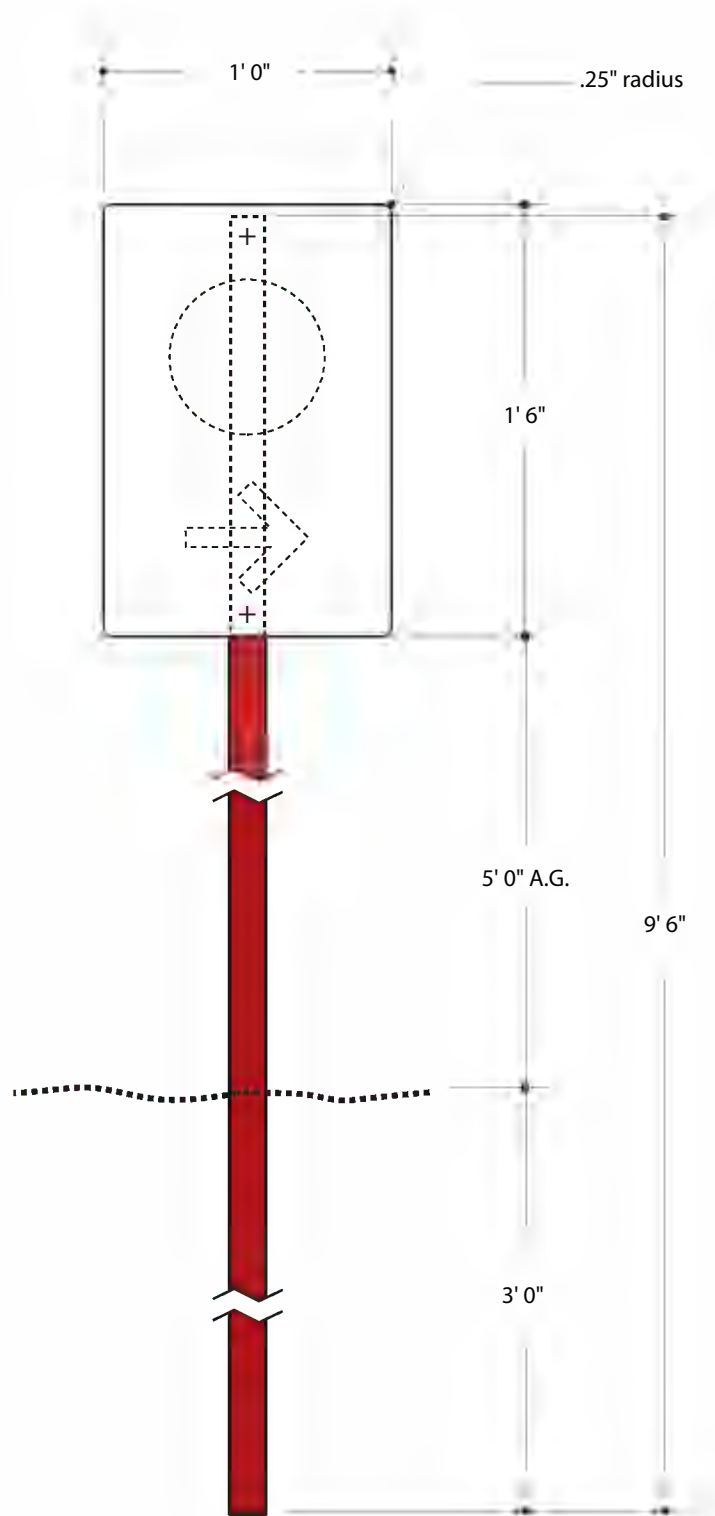

### GENERAL NOTES

**1** Sign panel is 3/32" or 1/8" aluminum with paint finish. Posts are standard perforated square tubes used for highway signing.

**2** Paint sign post to match GAP Red.

**3** Attach sign panel to posts with spanner head bolts. Use tamper resistant nuts with nylon inserts on backside.

**4** Auger holes for posts to depth exceeding frost line. Backfill holes with stone to level. Set posts and backfill with dry concrete and then soil. Ambient moisture and rain will harden footer. Apply grass seed or landscape material.

Front View

Scale 3' = 1' 0"



GAP Red

# TRAIL BLAZER

Graphic specifications

T6

### GENERAL NOTES

**1** Graphics are applied in two standard vinyl films on painted aluminum substrate, 3/32" thick. Select vinyl to match logo colors. See also pages 2.1 and 3.5 for complete color specifications.

**2** This sign panel can be ordered from [www.buildasign.com](http://www.buildasign.com).

**3** Do not use the standard arrows available at [www.buildasign.com](http://www.buildasign.com). Use only the arrow as shown here and specified on page 3.2.

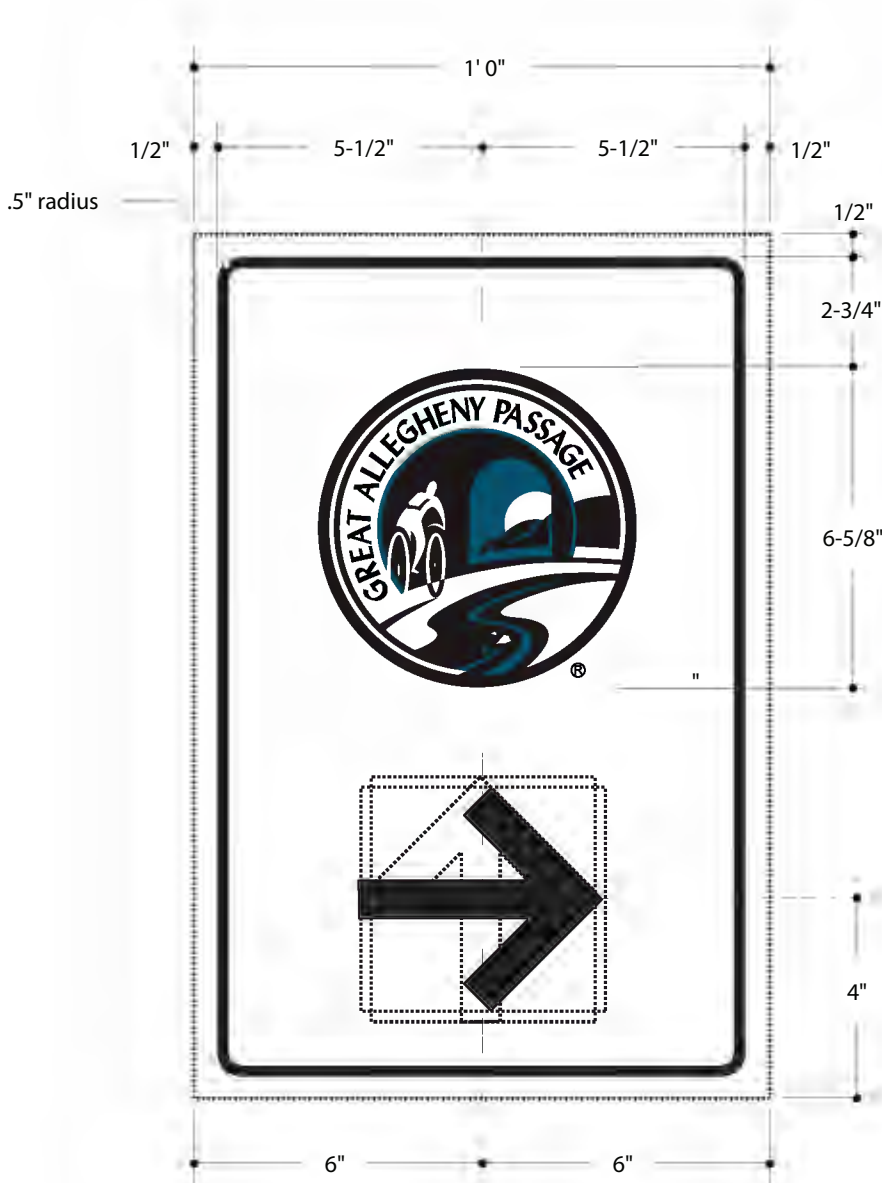

Detail: Graphic Panel  
Scale 3" = 1' 0"



# HERITAGE INTERPRETIVE SIGNS

## Overview

# T7

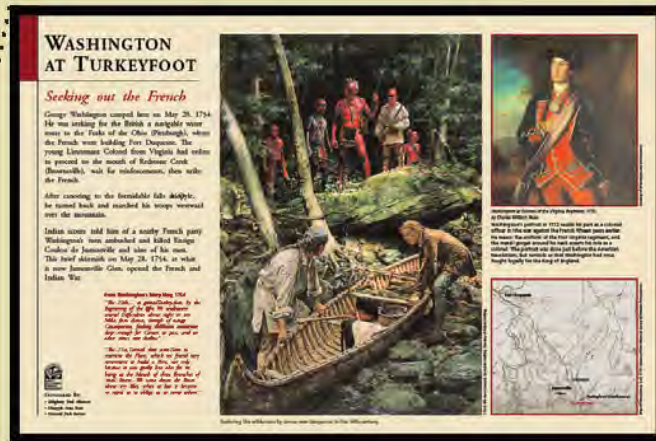

Heritage interpretive signs highlight explain invaluable scenic and historic sites along the trail, greatly enriching the trail user experience.

The interpretive panels are typically produced as a digital graphic which is embedded in fiberglass, making them highly vandal and weather resistant.

The sign structure is a welded steel frame painted with exterior grade polyurethane enamel.

The exhibit legs should be bolted to concrete footers, or set directly in augured holes exceeding the frost line. Backfill with stone to level, set posts, and then backfill with dry concrete. Ambient moisture and rainwater will harden footer.

Bally Design, designer of the trail side exhibit system, has implemented a number of exhibits to date. You may choose to work with Bally Design or another company to implement new interpretive exhibits. Contact the Allegheny Trail Alliance or The Trail Town Program for a list of approved design firms.

To date, sign panels and structures have been manufactured by Pannier Graphics. You may contact Pannier Graphics at [www.panniergraphics.com](http://www.panniergraphics.com) for your project, or contact the Allegheny Trail Alliance or The Trail Town Program for detailed specifications and a list of other approved fabricators.

5  
4  
3  
2  
1

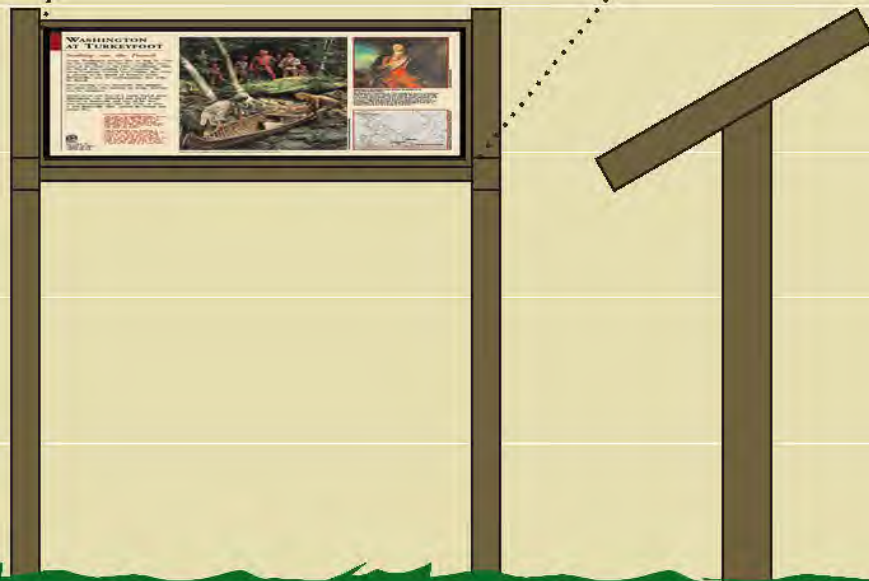

# HERITAGE INTERPRETIVE SIGNS T7

## Graphic specifications

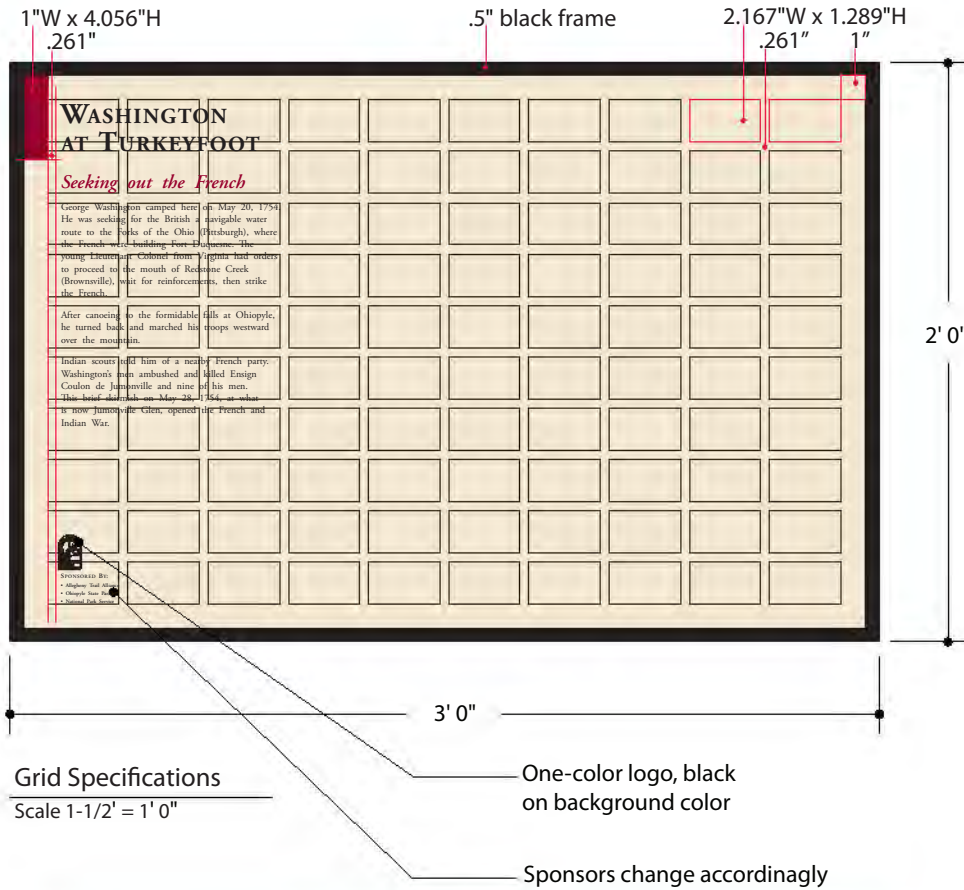

### GENERAL NOTES

- 1 Graphic panels are produced as high-resolution digital prints on paper substrate which is then embedded in fiberglass.
- 2 All heritage panels for the Great Allegheny Passage should follow these specifications.
- 3 Detailed typographic specifications follow on page 6.20.
- 4 Artwork should be prepared in Adobe Illustrator, Adobe InDesign, or similar illustration or page layout programs.
- 5 All photographs or illustrations should be a minimum 200 dpi at full size on the layout.
- 6 Your fabricator will have specific requirements. Confirm art requirements before beginning your project.

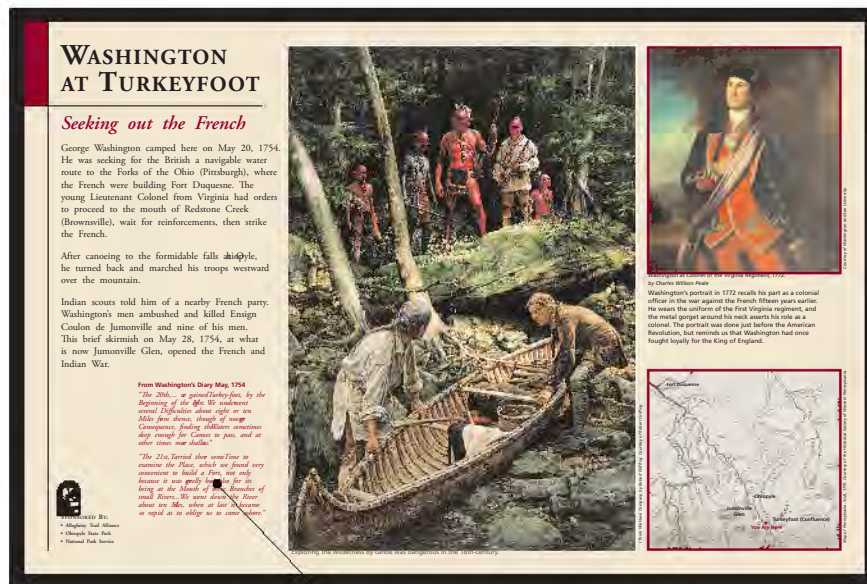

### Typical Layout

Scale 1-1/2' = 1' 0"

See page 6.20 for complete type specifications

### ACCENT COLORS

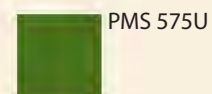

### BACKGROUND COLOR

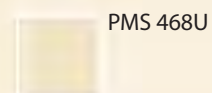



Head  
 Adobe Garamond  
 Small Caps  
 86/83  
 Tracking: 30  
 Kern as needed

# WASHINGTON AT TURKEYFOOT

Sub Head  
 Adobe Garamond Italic  
 58/68

## *Seeking out the French*

Primary Text  
 Adobe Garamond Regular  
 30/37

George Washington camped here on May 20, 1754. He was seeking for the British a navigable water route to the Forks of the Ohio (Pittsburgh), where the French were building Fort Duquesne. The young Lieutenant Colonel from Virginia had orders to proceed to the mouth of Redstone Creek (Brownsville), wait for reinforcements, then strike the French.

Quote Head  
 Adobe Frutiger Bold  
 19/24

Quote  
 Adobe Garamond Italic  
 23/25

### **From Washington's Diary May, 1754**

*"The 20th,... we gained Turkey-foot, by the Beginning of the Night. We underwent several Difficulties about eight or ten Miles from thence, though of no great Consequence, finding the Waters sometimes deep enough for Canoes to pass, and at other times more shallow."*

Secondary Text  
 Adobe Frutiger Roman  
 19/24

Washington's portrait in 1772 recalls his part as a colonial officer in the war against the French fifteen years earlier. He wears the uniform of the First Virginia regiment, and the metal gorget around his neck asserts his role as a colonel. The portrait was done just before the American Revolution, but reminds us that Washington had once fought loyally for the King of England.

Captions  
 Adobe Frutiger Italic  
 16/24

*Washington as Colonel of the Virginia Regiment, 1772.  
 by Charles Willson Peale*

Credits  
 Adobe Frutiger Italic  
 12/12

*I Think We Have Company, by Robert Griffing. Courtesy of Robert Griffing.*

Only these fonts and paragraphs styles should be used when creating artwork for heritage interpretive panels. Fonts can be purchased from Adobe Systems or its authorized dealers.

See [www.adobe.com/type](http://www.adobe.com/type).

If you are laying out heritage panel without professional assistance, be aware of common typesetting errors of beginning typesetters, including widows, orphans, poorly ragged copy, inappropriate use of foot and inch marks for apostrophes and quote marks, and more.

You can find out more about these typesetting terms and other typesetting best practices in the art and design section of your library or at larger bookstores.

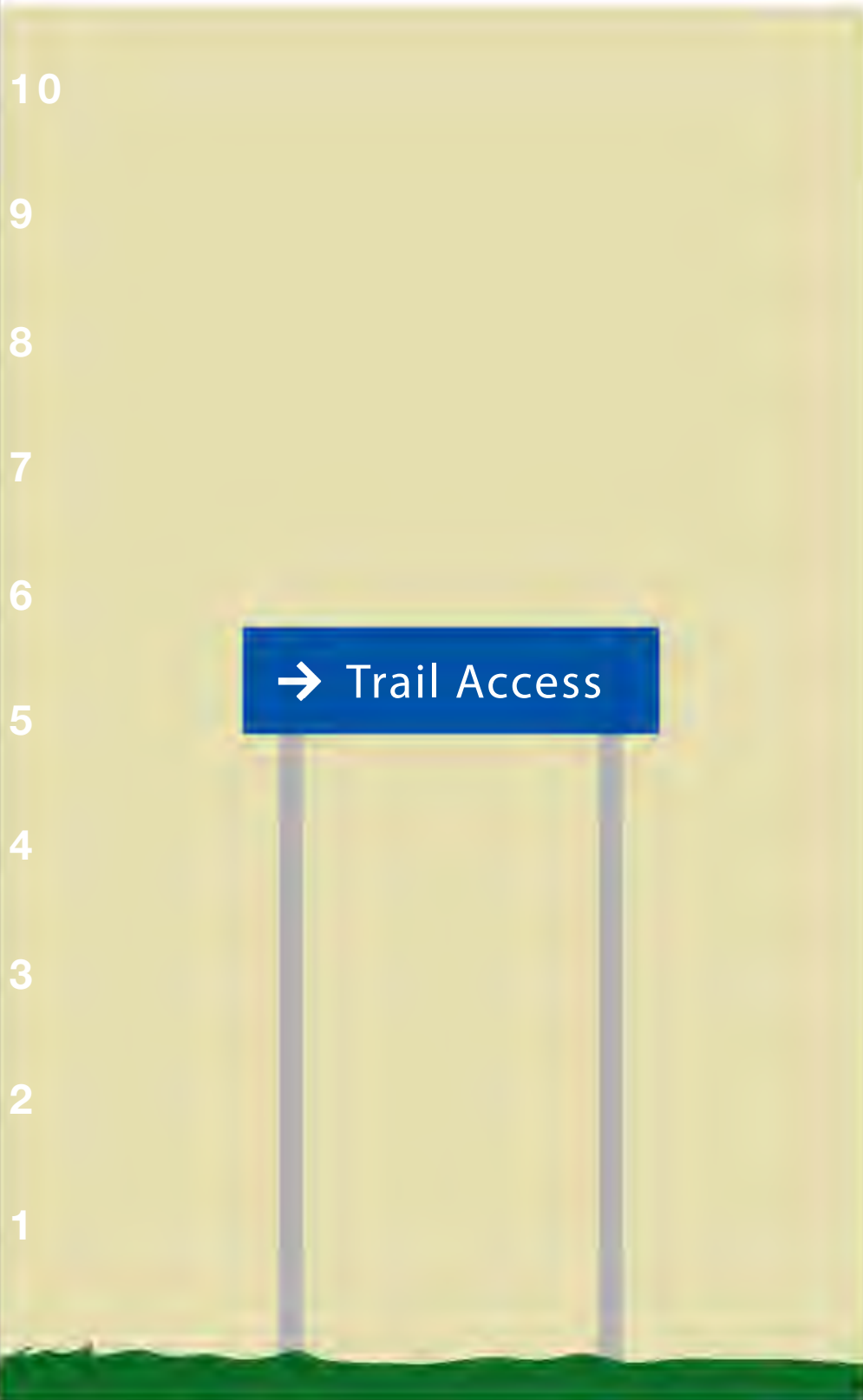

Supplemental wayfinding signs help trail users find trail access areas after leaving state and regional roadway systems. Typically located at intersections of local roads where the driver must make a directional decision, they include only one message, Trail Access, and an arrow pointing left, up, or right.

The sign colors are intended to relate to general roadway sign systems rather than the Great Allegheny Passage. The lettering and arrows are applied in reflective white vinyl, for good nighttime visibility.

# SUPPLEMENTAL WAYFINDING R1

Construction

## GENERAL NOTES

- 1 Sign panel is made from 3/32" or 1/8" steel or aluminum sheet, with automotive grade polyurethane enamel paint finish.
- 2 Posts are standard perforated square tubes used for highway signing.
- 3 Attach sign panel to posts with spanner head bolts. Recommend using tamper resistant nuts with nylon inserts on backside.
- 4 Auger holes for posts to depth exceeding frost line. Backfill holes with stone to level. Set posts and backfill with dry concrete and then soil. Ambient moisture and rain will harden footer. Apply grass seed or landscape material.

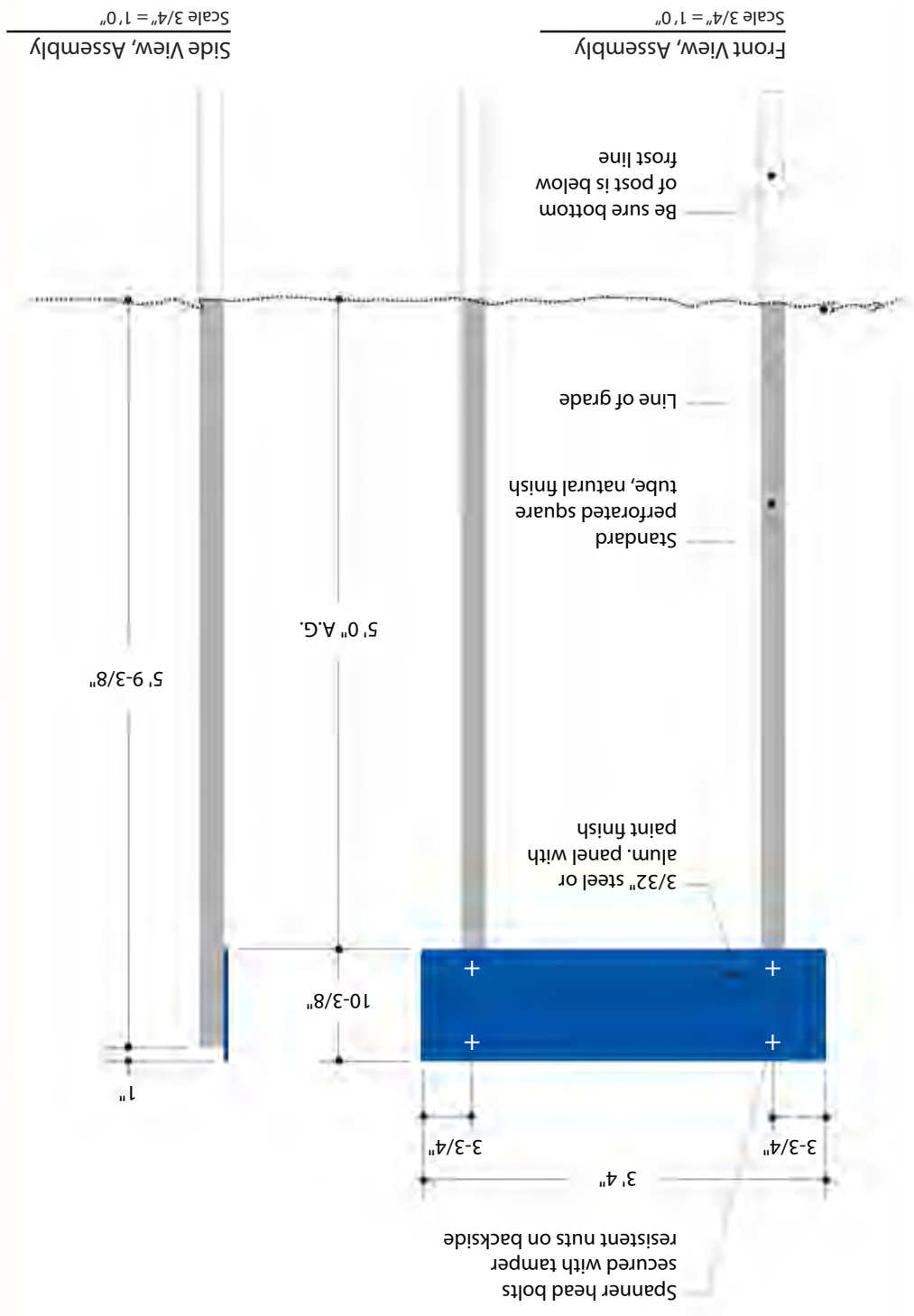

# SUPPLEMENTAL WAYFINDING

## Graphic specifications

R1



Detail: Typical Graphic Panels  
Scale 1" = 1' 0"

FONT T2\*

\*NOTE: Tahoma Regular  
May be substituted if ordering  
this sign online through  
[www.buildasign.com](http://www.buildasign.com)

### GENERAL NOTES

- 1 Lettering and arrows are applied in white reflective vinyl to painted substrate panel.
- 2 This sign panel can be ordered from [www.buildasign.com](http://www.buildasign.com).
- 3 If ordering this sign online from [www.buildasign.com](http://www.buildasign.com), the type face Tahoma Regular can be substituted for Myriad Pro Regular.
- 4 Do not use the standard arrows available at [www.buildasign.com](http://www.buildasign.com). Use only the arrow as shown here and specified on page 3.2.
- 5 Lettering is tracked to 50 units for greater legibility to drivers.
- 6 Attach sign panel to posts with spanner head bolts. Paint bolt heads to match panel.

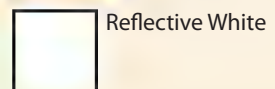

## REVERSE WAYFINDING

R2

Overview

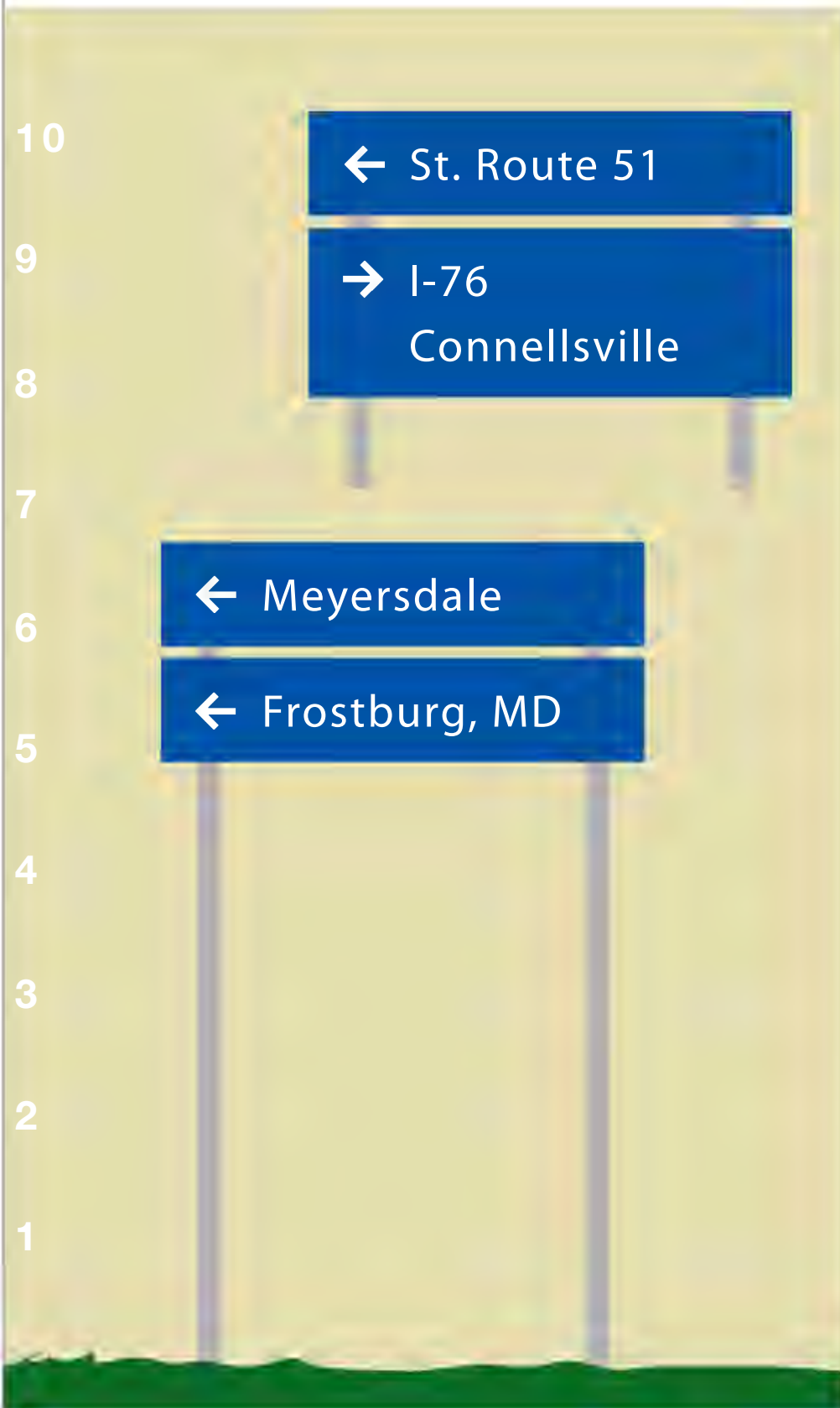

Reverse wayfinding signs help trail users get back on local roadways going in the right direction, after they have enjoyed the trail. Typically located opposite access area parking lots, they indicate next significant town or roadways on the drivers left and on their right, or possibly ahead of them. The sign colors are intended to relate to general roadway sign systems rather than the Great Allegheny Passage. The lettering and arrows are applied in reflective white vinyl, for good nighttime visibility.

# REVERSE WAYFINDING

R2

## Construction

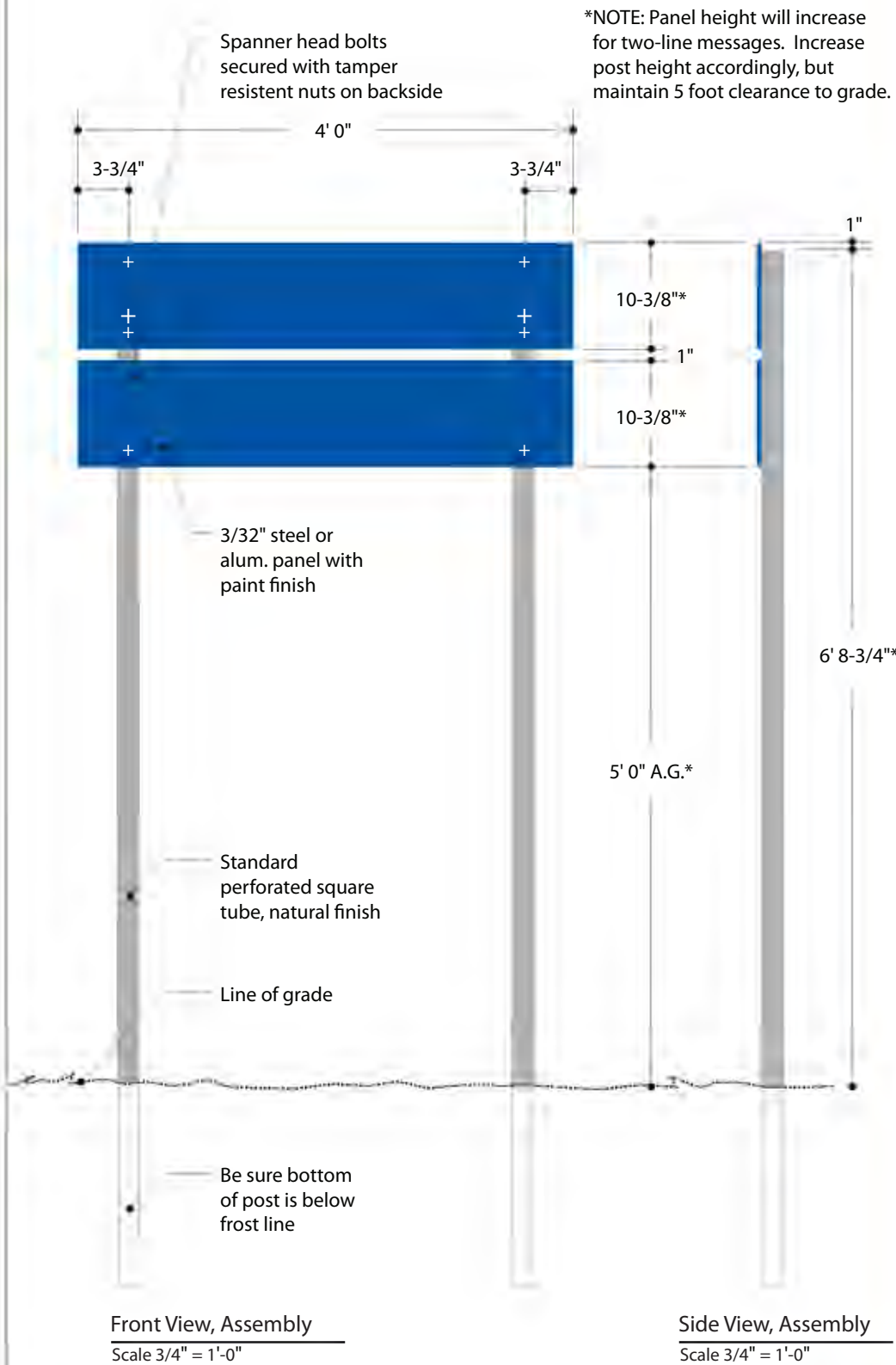

### GENERAL NOTES

- 1 Sign panel is made from 3/32" or 1/8" steel or aluminum sheet, with automotive grade polyurethane enamel paint finish.
- 2 Posts are standard perforated square tubes used for highway signing.
- 3 Attach sign panel to posts with spanner head bolts. Recommend using tamper resistant nuts with nylon inserts on backside.
- 4 Auger holes for posts to depth exceeding frost line. Backfill holes with stone to level. Set posts and backfill with dry concrete and then soil. Ambient moisture and rain will harden footer. Apply grass seed or landscape material.

# REVERSE WAYFINDING

R2

## Graphic specifications

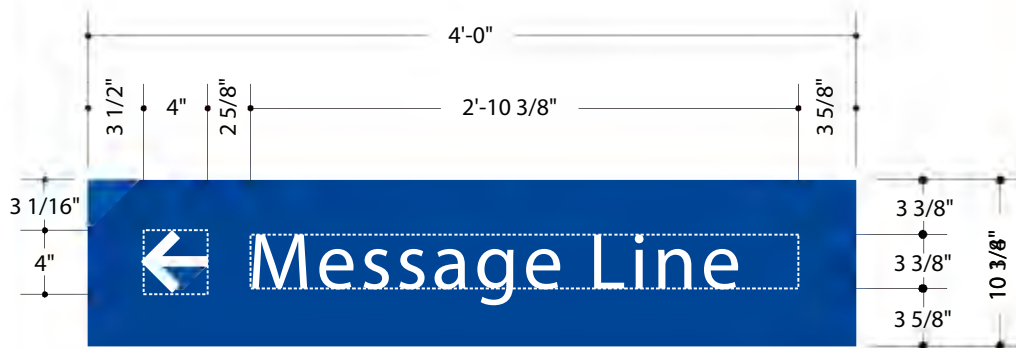

One-Line Message Panel

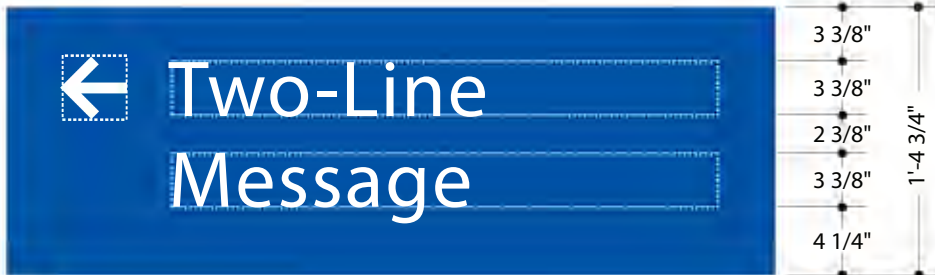

Split-Line Message Panel

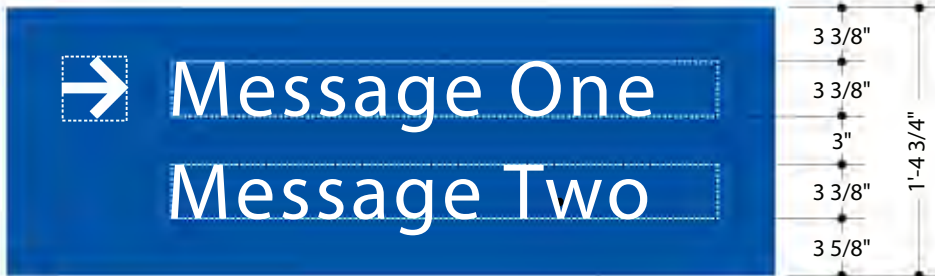

Two-Message Panel

Detail: Graphic Layout

Scale 1"=1'-0"

FONT T2\*

\*NOTE: Tahoma Regular  
May be substituted if ordering  
this sign online through  
[www.buildesign.com](http://www.buildesign.com)

### GENERAL NOTES

- 1 Lettering and arrows are applied in white reflective vinyl to painted substrate panel.
- 2 This sign panel can be ordered from [www.buildesign.com](http://www.buildesign.com).
- 3 If ordering this sign online from [www.buildesign.com](http://www.buildesign.com), the type face Tahoma Regular can be substituted for Myriad Pro Regular.
- 4 Do not use the standard arrows available at [www.buildesign.com](http://www.buildesign.com). Use only the arrow as shown here and specified on page 3.2.
- 5 Lettering is tracked to 50 units for greater legibility to drivers.
- 6 Attach sign panel to posts with spanner head bolts. Paint bolt heads to match panel.
- 7 Messages outlined in dashed boxes may change. The dashed box indicates maximum extent of copy.

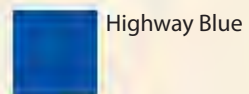

Highway Blue



Reflective White